

Motocross

Standing Regulations

SECTION 1 MEETINGS

1.1	Definitions	132
1.2	Categories of Meetings	132
1.2.1	International	132
1.2.2	European Open	132
1.2.3	National	132
1.2.4	Open	133
1.2.5	Restricted	133
1.3	Supercross	133
1.4	Beachcross	133
1.5	Minibike	133
1.6	Eligibility of Foreign Riders in National, Open and Restricted Meetings	133
1.7	Practice Meetings and Test Days	133
1.8	Conditions for Motocross Meetings	134

SECTION 2 ELIGIBILITY

2.1	Licences	134
2.2	Capacity and Licence Restrictions	135
2.3	Youth	138
2.4	Adult	138
2.5	Physical Eligibility/Proficiency Assessment	138

SECTION 3 CLASS VARIATIONS

3.1	Automatic Class	138
3.2	65cc Junior Class	138
3.3	85cc Small Wheel and 85cc Big Wheel Classes	138
3.4	Open Class (Youth)	139
3.5	MX2	139
3.6	MX1	139
3.7	Open (Adult)	139
3.8	Formula Classes	139
3.9	50cc Quad Class	139
3.10	100cc Quad Class	139
3.11	250cc Quad Classes (Youth)	139

SECTION 4 LICENCES AND REGISTRATIONS (OFFICIALS)

4.1	Licensed Officials	139
4.1.1	Clerk of the Course/Race Director	140
4.1.2	Steward/Referee	140
4.1.3	Chief Technical Officer	140
4.1.4	Measurer	140
4.1.5	Timekeepers	140
4.2	Unlicensed Officials	140
4.2.1	Incident Officer	141
4.2.2	Secretary of the Meeting	141
4.2.3	Club Stewards	141
4.2.4	Marshal	141
4.2.5	Medical Officer	141

SECTION 5 SPECIFICATION OF MOTORCYCLE

5.1	Brakes	141
-----	--------	-----

5.2	Tyres	141
5.3	Mudguards	142
5.4	Clutch and Brake Levers	142
5.5	Footrests and Handlebars	142
5.6	Lamps	142
5.7	Throttle	142
5.8	Exhaust Pipes	142
5.9	Running Of Engines	142
5.10	Fuel	142
5.11	Ignition Cut-Out	142
5.12	Chain Guards	143
5.13	Construction	143
5.14	Wheels	143
5.15	Engines	143
5.16	Miscellaneous	143

SECTION 6 NUMBER PLATES

6.10	Number Plate Diagram	145
------	----------------------	-----

SECTION 7 TECHNICAL CONTROL 146

SECTION 8 SAFETY

8.1	Medical Services	147
8.2	Clothing	148
8.2.1	Motocross, Supercross and Beachcross	149
8.2.2	Minibike	149
8.3	Track Safety	149
8.4	Fire Extinguishers	149
8.5	Riding In The Paddock	149
8.6	Track Access	149
8.7	Flag Signals	150

SECTION 9 RACE MANAGEMENT

9.1	Entries	150
9.2	Practice	150
9.3	Start Positions	150
9.4	SIGHTING LAP	151
9.5	Electronic Timekeeping	151
9.6	Races	151
9.7	Method of Starting	151
9.8	Starter's Orders	151
9.9	False Starts	152
9.10	Stopping a Race	152
9.11	Finish of Race	152
9.12	Race Results	153
9.13	Change of Machine	153
9.14	Change of Sidecar Passenger	153
9.15	Outside Assistance	153
9.16	Foul, Unfair or Dangerous Riding	153
9.17	Course Conduct	153
9.18	Awards	153

SECTION 10 GENERAL

10.1	Instructions to Riders	154
10.2	Conduct	154
10.3	Parental Responsibility	154
10.4	Declaration	154
10.5	Compliance with Regulations	154
10.6	Dogs at Off Road Motorcycle Events	154

SECTION 11 BEACHCROSS

11.1	Specification of Motorcycle	154
11.2	LPG Fuel/Diesel	154
11.3	Circuit	154
11.4	Starter's Orders	155
11.5	Finish of a Race	155
11.6	Duration of a Race	155
11.7	Interruption of a Race	155
11.8	Disqualifications	155

SECTION 12 CROSS COUNTRY QUADS STANDING REGULATIONS

12.1	Meetings	155
12.2	Eligibility	155
12.3	Class Variations	156
12.4	Licences And Registrations (Officials)	157
12.5	Specification Of A Motorcycle	157
12.6	Number Plates	157
12.7	Technical Control	157
12.8	Safety	157
12.9	Race Management	158
12.10	General	159

SECTION 13 GRADING

13.1	ACU Motocross Riders Expert Grading Scheme (Adult)	160
------	--	-----

SECTION 14 MOTOCROSS MOTORCYCLE 161

The National Sporting Code of the ACU and the Standing Regulations together with the Supplementary Regulations and any Final Instructions shall apply to all Motocross Events held under an ACU Permit.

SECTION 1 MEETINGS

1.1 DEFINITIONS

- **FIM** – Fédération Internationale de Motorcyclisme – The international governing body of motorcycle sport
- **FIME** – Fédération Internationale de Motorcyclisme Europe – European governing body for motorcycle sport
- **FMN** – Federation Motorcycliste Nationale – FIM affiliated National federations
- **ACU** – Auto Cycle Union – The FMN of the FIM for the British Isles excluding Northern Ireland
- **SACU** – Scottish Auto Cycle Union
- **MCUI** – Motor Cycle Union of Ireland – The FMN of the FIM for Ireland
- **IMN** – International Meeting Number issued by the FIM

1.2 CATEGORIES OF MEETINGS

- Restricted Meetings
- Open Meetings
- National Meetings
- European Open Meetings
- International Meetings

1.2.1 INTERNATIONAL

1. The Permit shall be issued by ACU Headquarters for a meeting inscribed on the International Calendar of the FIM and having an FIM International Meeting Number (IMN).
2. An International meeting is open to Entrants and Riders of more than one nation who must hold an International Licence or a National licence issued by the ACU, the SACU or their FMN valid for the particular meeting concerned.
3. All riders not holding a licence issued by the ACU or SACU must carry proof of Insurance and a written Start Permission document issued by their FMN.

Note: This includes all riders holding a licence issued by the MCUI.

1.2.2 EUROPEAN OPEN

1. The permit shall be issued by ACU Headquarters for a meeting inscribed on the Calendar of the Fédération Internationale de Motorcyclisme Europe (FIME) and having a European Meeting Number (EMN).
2. A European Open meeting is open to Entrants and Riders of more than one European nation who must hold the appropriate Competition Licence valid for the particular meeting concerned.
3. All riders not holding a Licence issued by the ACU or SACU must carry proof of Insurance and a written Start Permission document issued by their FMN.

Note: This includes all riders holding a licence issued by the MCUI.

1.2.3 NATIONAL

1. The Permit shall be issued by ACU Headquarters.
2. A National meeting is open to Entrants and Riders who are the holders of an ACU Motocross or International Motocross Licence issued by the ACU, SACU or any FMN valid for the particular meeting concerned.
3. All riders not holding a Licence issued by the ACU or SACU must carry proof of Insurance and a written Start Permission document issued by their FMN.

Note: This includes all riders holding a licence issued by the MCUI.

1.2.4 OPEN

1. The Permits for events run under basic insurance are issued by ACU Headquarters.
2. The Permits for events run under Premier insurance are issued by the Centre to which the club is affiliated.
3. An Open meeting is open to Entrants and Riders who are the holders of a Licence issued by the ACU, SACU or any FMN valid for the meeting concerned.
4. All riders not holding a Licence issued by the ACU or SACU must carry proof of Insurance and a written Start Permission document issued by their FMN.

Note: This includes all riders holding a licence issued by the MCUI.

1.2.5 RESTRICTED

1. The Permits for events run under basic insurance are issued by ACU Headquarters.
2. The Permits for events run under Premier insurance are issued by the Centre to which the club is affiliated.
3. A Restricted meeting is open to Entrants and Riders who are the holders of a current Licence issued by the ACU, SACU or any FMN valid for the meeting concerned.
4. The Supplementary Regulations issued for the event must specify all restrictions and requirements of eligibility.

Note: This includes all riders holding a licence issued by the MCUI.

1.3 SUPERCROSS

1. Arena/Supercross is defined as a motorcycle event conducted in a stadium type facility, open or fully closed, using Motocross motorcycles.
2. The permits for Supercross events are issued by ACU Headquarters.
3. Supercross events may be run under any of the above categories.

1.4 BEACHCROSS

1. The permits for Beachcross are issued by ACU Headquarters.
2. Beachcross events may be run under any of the above categories.

1.5 MINIBIKE

1. The permits for Minibike events are issued by ACU Headquarters.
2. Minibike events may be run under any of the above categories.

1.6 ELIGIBILITY OF FOREIGN RIDERS IN NATIONAL, OPEN AND RESTRICTED MEETINGS

1. The Supplementary Regulations issued for the event must specify the licence qualification and eligibility requirements of foreign riders.
2. All riders must have a current Licence and Start Permission from their own Federation valid for the event.
3. Foreign competitors from FIME member countries who are not in possession of a start permission of their home FMN or evidence of FIM standard insurance cover pay the insurance premium of £95.00. The sum comprises £15.00 in lieu of an one event licence and £80.00 for repatriation cover.
4. Repatriation insurance is restricted to competitors from member countries of the FIME.
5. Riders outside of the countries of the FIME will need to be quoted separately from ACU House.

1.7 PRACTICE MEETINGS AND TEST DAYS

1. Permits for Practice Meetings and Test Days may be issued on application to ACU

Headquarters. (Please request a copy of the Practice Permit Guidelines from the ACU Head Office when applying for this type of permit)

- No such event may be held unless the appropriate Permit and Insurance has been issued.

1.8 CONDITIONS FOR MOTOCROSS MEETINGS

- The organiser must be affiliated or approved by the ACU.
- The venue must hold a current Track Certificate issued by the ACU.
- The permit issuing authority must approve the Supplementary Regulations for the event and issue an ACU Permit prior to publication and circulation. Applications should be made at least six weeks prior to the meeting date.
- The race office must remain operative with all equipment in place until the end of the period provided for the lodging of a protest or appeal, and all officials and marshals must remain at the circuit and available to the Clerk of the Course and the Stewards during that period.

SECTION 2 ELIGIBILITY

2.1 LICENCES

- For National competitions, entrants, riders and passengers must hold a current competition licence for International or National events issued by the Auto Cycle Union, Scottish Auto Cycle Union or any FMN.
- For all competitions of below National status, a current competition licence is required.
- Day Licences. A One Event Competition Licence grants the same benefits of an annual licence for the duration of one event only and is available for Motocross, Supercross, Beachcross or Minibike events up to and including National status.
- Riders in possession of a Motocross Dual (youth open/adult MX) licence may compete in either Youth or Adult motocross events. Riders must choose the class at the time of entry as it is not permitted to compete on both Youth and adults races at one meeting. (This is not applicable to Supercross).
- Details of eligibility will be found in the Supplementary Regulations of the event.
- Youth only: All new applications must be accompanied by a photocopy of the rider's birth certificate.

Youth Solo

Age on 1 Jan	Grade	Engine Capacity	Maximum Wheel Size/ Specification
6–7 years	Automatic A	Minimum 49cc 2 or 4 stroke. Maximum	12 inch rear, 15 inch front
6–8 Years	Automatic B	50cc 2 or 4 stroke automatic, no manual clutch	
7–10 years	65cc Junior	Minimum 60cc 2 stroke or 85cc 4 stroke. Maximum 65cc 2 stroke or 110cc 4 stroke	12 inch rear, 14 inch front
9–12 years	85cc Small Wheel, Intermediate	Minimum 70cc 2 stroke or 125cc 4 stroke. Maximum 85cc 2 stroke or 150cc 4 stroke	14 inch rear, 17 inch front
11–15 years	85cc Big Wheel, Senior	Minimum 70cc 2 stroke or 125cc 4 stroke. Maximum 85cc 2 stroke or 150cc 4 stroke	16 inch rear, 19 inch front
14–17 years	Open (Youth)	Minimum 120cc 2 stroke or 175cc 4 stroke Maximum 150cc 2 stroke or 250cc 4 stroke	19 inch rear, 21 inch front

Youth Solo Riders may continue in the youth open class until the end of the year in which their 18th birthday falls.

2.2 CAPACITY AND LICENCE RESTRICTIONS

Adult Solo

Age on 1 Jan	Engine Capacity
15 Years	Minimum 120cc up to maximum 650cc 2 stroke Minimum 175cc up to maximum 650cc 4 stroke

Sidecar

Age on 1 Jan	Grade	Specification
15 Years	Driver	Over 350cc and up to 1000cc 4 stroke and up to 750cc 2 stroke
15 Years	Passenger	

Adult Quad

15 Years	Up to 550cc max 2 cylinders 2 stroke
15 Years	Up to 800cc 4 stroke max 1 cylinder

Youth Quad

All classes (*excluding 250cc stock) are allowed to replace or enhance wheels, tyres, drive sprocket, chains, axle, a-arms, bumpers, grab bars, suspension, brakes and steering. All quads are required to have fitted a lanyard cut out switch, nerf bars and front and rear number boards. Any lights must be removed.

Age	Max cc	Type	Specification
6–9 years	50cc Standard	50cc Automatics	Automatic Production Quads built by the manufactures. There will be no modifications whatsoever allowed to engine, exhaust, carburettor, air box, clutch, electrics etc. Frame and engine must be by the original manufacturer. Engines must not have exceeded 50cc at time of manufacture.
7–9 years	50cc Modified	50cc Automatics	Automatic Quads. Performance Modifications are allowed up to a maximum of 50cc. Engines must not have exceeded 50cc at time of manufacture.
8–13 years	100cc Standard	Max 100cc 2 stroke Auto Max 150cc 4 stroke Auto	Automatic Production Quads built by the manufactures. There will be no modifications whatsoever allowed to engine, exhaust, carburettor, air box, clutch, electrics etc. Frame and engine must be by the original manufacturer. Engines must not have exceeded 100cc 2 stroke or 150cc 4 stroke at time of manufacture.
9–13 years	100cc Modified	Max 100cc 2 stroke Max 150cc 4 stroke	Automatic Production Quads. Performance Modifications are allowed to the engine up to a maximum of 100cc 2 stroke or 150cc 4 stroke. Engines must not have exceeded 100cc 2 stroke or 150cc 4 stroke at time of manufacture.
9–14 years	100cc Geared	Max 100cc 2 stroke Max 150cc 4 stroke	Geared Production Quads. Performance Modifications are allowed to the engine up to a maximum of 100cc 2 stroke or 150cc 4 stroke. Engines must not have exceeded 100cc 2 stroke or 150cc 4 stroke at time of manufacture.

8–13 years	125cc Geared Standard	Max 125cc Air Cooled 4 stroke	Geared Production Quads. There will be no modifications allowed to the engine, exhaust, carburetor, air box, clutch, electrics etc. Frame and engine must be by the original manufacturer.
9–13 years	125cc Geared Modified	Max 125cc Air Cooled 4 stroke	Geared Production Quads. Performance modifications are allowed to the engine up to a maximum of 125cc 4 stroke. Engines must not have exceeded 125cc 4 stroke at time of manufacture.
11–16 years	150cc 4 stroke	Max 150cc 4 stroke	Engines must not have exceeded 150cc 4 stroke at the time of manufacture
11–16 years	*250cc Stock	Yamaha 250cc Raptor	Factory Delivered Spec + Optional Steering Damper, throttle & handlebar choice.
11–16 years	250cc Standard	200cc 2 stroke 250cc aircooled 4 stroke	Production Quads built by the manufactures. There will be no modifications whatsoever allowed to engine, exhaust, carburettor, air box, clutch, electrics etc. Frame and engine must be by the original manufacturer. Engines must not have exceeded 200cc 2 stroke or 250cc 4 stroke at time of manufacture
12–16 years	250cc Race & Production & Modified	200cc 2 stroke 250cc air-cooled 4 stroke.	Modifications allowed to the engine, exhaust suspension etc. Engines must not exceed 200cc 2 stroke or 250cc 4 stroke at time of manufacture.
14–17 years	250cc Open	250cc 4 stroke	Modifications allowed to the engine, exhaust suspension etc.

Adult Mini Bike

Age on 1 Jan	Grade	Specification
15 Years	50cc Pro Mini	Wheel size: must be maximum 10" rear and 10" or 12" front. Engine – Must be maximum 50cc. No stroker cranks. Permitted engine mods include: Piston, Cylinder head porting, (valves are to remain stock Honda XR/CRF50 size), Camshaft, carburettor, racing ignitions, air filter and exhausts. Transmission: Must be stock semi automatic, Permitted mods include replacement semi auto clutch units, close ratio transmissions, heavy duty clutch springs. Rolling chassis – Unlimited mods allowed
15 Years	10" Pro Mini	Wheel size: must be maximum 10" rear and 10" or 12" front. Engine – Must be maximum 140cc, using stock Honda stroke/ crank and 52mm bore. Any cylinder head, camshaft, piston permitted. Any ignition. Transmission. Can use manual clutch, close ratio transmission. Rolling chassis – Unlimited mods allowed.

15 Years	Superstock Midsize	This is a one make class based around the Kawasaki KLX110. The only other permitted bike in this class is a 2005 Suzuki DRZ110. Wheel size: must be maximum 12" rear and 12" or 14" front. Engine – Must be maximum 110cc. using stock cylinder head – no head modifications allowed. Replacement camshaft permitted, Must use stock piston and cylinder – no stroker cranks. Carburettor must be stock, including choke, air filter, Transmission – Must use stock clutch, heavy duty clutch springs permitted. Chain and sprockets permitted, Rolling chassis – must use stock frame and swingarm – replacement rear shock absorber allowed. Forks – must use stock forks sliders and fork legs – replacement springs and internal mods permitted. Wheels – Must use stock hubs, rim and spoke upgrades permitted. Oil Coolers can be used. Can change Handle bars, Handlebar clamps, Throttle, cables, seat, plastics, footpegs and footpeg mount, gear shifter, brake pedal, skid plate, tyres.
15 Years	Midsize	Wheel size: must be maximum 12" rear and 12" or 14" front. Engine Must be maximum 160cc. Any cylinder head, camshaft, piston permitted. Any ignition. Transmission. Can use manual clutches and close ratio transmission. Rolling chassis – Unlimited mods allowed

Youth Mini Bike

Age on 1 Jan	Grade	Specification
6–9 Years	50cc	Machines are to be based on a horizontal single cylinder four stroke with a maximum capacity of 50cc. Wheel size must not exceed 10" rear. Exhaust pipes, bars, wheels tyres, sprockets, shocks and rev-boxes, CDI's can be upgraded, but the engine must remain as stock. No cams, no modifications of stock parts on engine. No Stroker cranks allowed.
9–12	88cc	Machines are to be based on a horizontal single cylinder four stroke with a maximum capacity of 88cc. Carburettors must not be bigger than 20mm. The head must be stock, Twin sparks and super heads are not allowed. Wheel size must not exceed 10" rear. Exhaust and suspension upgrades are allowed. Big valved heads are allowed along with Takawa super heads and other brand heads. No Stroker cranks allowed.
12–15	111cc	Machines are to be based on a horizontal single cylinder four stroke with a maximum capacity of 111cc. Full tuning of engine is permitted provided the displacement rule of 111cc is not exceeded. Wheel size must not exceed 12" rear 14" front. Full exhaust and suspension modifications are permitted.

After reaching 15 years of age riders can apply for an adult solo Motocross licence and still retain a youth open licence until the end of the year in which their 18th birthday falls.

After reaching 15 years of age riders can apply for an adult quad Motocross licence and still retain a 250 youth licence until the end of the year in which their 18th birthday falls. (See 2.2 Capacity and Licence Restrictions).

2.3 YOUTH

1. Within the above limits youth riders will compete during the 2015 season in classes determined by date of birth. Riders may ride in a lower class for experience on a non-award basis.
2. No rider may compete before his/her sixth birthday.
3. When a rider reaches the maximum age limit for his/her group, he/she may continue to compete in that group until the end of the calendar year.
4. On reaching the minimum age for the next group, the rider may upgrade. Please note that any rider who chooses to upgrade cannot then move back to the lower capacity class once they have competed at the higher level. (With the exception of competing in the British MXY2 or Supercross Championships).
5. Any rider upgrading before the required minimum age is reached will be subject to disciplinary action unless officially upgraded by the Motocross Department.
6. An assessment will be required for any rider wishing to ride in a class of which they do not reach the age requirement to be arranged by the rider following application to the ACU Motocross Department.
7. The parent or legal guardian must accompany a youth competitor under the age of 18 to any meeting and stay for the entire duration of the time that the rider is present.
8. Riders in possession of a Motocross Dual (youth open/adult MX) licence may compete in either youth or adult motocross events. Riders in possession of an ATV/Quad Dual (youth 250cc Adult Quad) licence may compete in either youth or adult motocross events. Riders must choose the class at the time of entry as it is not permitted to compete on both Youth and adults races at one meeting. (This is not applicable to Supercross)

2.4 ADULT

1. The parent or legal guardian must accompany a youth competitor under the age of 18 to any meeting and stay for the entire duration of the time that the rider is present.
2. No rider will be permitted to compete in the adult classes until they reach the minimum required age and hold the correct licence.

2.5 PHYSICAL ELIGIBILITY/PROFICIENCY ASSESSMENT

All youth riders should be able to sit astride their machines and with one foot firmly on the ground must be able to control the gear lever or the foot brake with the other foot.

SECTION 3 CLASS VARIATIONS

3.1 AUTOMATIC CLASS

1. Clubs may run the Auto and Junior classes together.
2. Where there is direct conflict between large and small machines, clubs at their discretion may separate them into two classes.
3. Parents are permitted to hold the rear of the machine immediately prior to the start of the race, they must be signed on and wearing an appropriate identification bib or sash to assist their rider before going on to the course.
4. Clubs may choose whether they run Automatic A or Automatic B classes but must state clearly which class will be run in the Supplementary Regulations.

3.2 65CC JUNIOR CLASS

Clubs may run the Junior and Auto classes together.

3.3 85CC SMALL WHEEL AND 85CC BIG WHEEL CLASSES

Clubs may run 85cc Small Wheel and 85cc Big Wheel together.

3.4 OPEN CLASS (YOUTH)

The Open Class will not be permitted to run in a joint class with the 85cc BW Class nor with adult competitors.

3.5 MX2

120cc to 150cc twostroke or 175cc to 250cc fourstroke.

3.6 MX1

Over 175cc to 250cc twostroke or 251cc to 450cc fourstroke.

3.7 OPEN (ADULT)

All solo machines 120cc twostroke or 175cc fourstroke up to 650cc two or fourstroke.

3.8 FORMULA CLASSES

For older machines can also be catered for at events i.e. pre 65, pre 75, twinshock.

3.9 50CC QUAD CLASS

50cc Quad classes may be run together but must be run separately from all other classes, unless approval is given by the Motocross Committee.

3.10 100CC QUAD CLASS

100cc Quad classes may be run together but must be run separately from all other classes, unless approval is given by the Motocross Committee.

3.11 250CC QUAD CLASSES (YOUTH)

250cc Quad classes may be run together but must be run separately from all other classes.

SECTION 4 LICENCES AND REGISTRATIONS (OFFICIALS)

Motocross Race Officials are required to hold an ACU Licence of the appropriate grade for the performance of their duties. The minimum age for motocross licenced officials is 18 years. Licences for officials will be issued free of charge.

4.1 LICENCED OFFICIALS

Motocross, Supercross, Beachcross and Minibike Officials who require a Licence

	See Note Below	Licence Required	Attendance at Seminar/ Training Session
Clerk of the Course	1	YES	3 YEARS Every Third Year maximum
Race Director	National Only	YES	3 YEARS Every Third year maximum
Steward/Referee	2	YES	3 YEARS Every Third Year maximum
Chief Technical Officer	3	YES	3 YEARS Every Third Year maximum
Sound Inspector		YES	3 YEARS Every Third Year maximum
Measurer	4	YES	3 YEARS Every Third Year maximum
Timekeeper	5	YES	By Assessment

Clubs and Centres shall only nominate candidates whose aptitude and integrity for the position they can fully justify. Official ACU approval and the issue of a Licence is only after the candidates have proved to be competent according to the special requirements for each discipline. The respective Committees and Panels organise seminars that are compulsory for certain officials. A Licence, obtained following the successful completion of a seminar, is valid for 3 years.

4.1.1 CLERK OF THE COURSE/RACE DIRECTOR

1. **DEFINITION.** Refer to the National Sporting Code
2. **AGE LIMITS.** There are no upper age limits for Motocross Clerks of the Course of all grades. A Clerk of the Course must be physically able to reach all parts of the circuit to carry out his or her duties.
3. **GRADES – Motocross/Supercross**
 - a) **National.** A Clerk of the Course who may officiate at any event held under an ACU permit. May officiate as Deputy or Assistant to an FIM International Clerk of the Course.
 - b) **Regional.** A Clerk of the Course who may officiate at any event held under an Open or Restricted Permit.
4. **Upgrading.** To upgrade from Regional to National an official must have the recommendation of their club, centre or region or be recommended by the Motocross Committee.

4.1.2 STEWARD/REFEREE

1. **DEFINITION.** Refer to the National Sporting Code
2. **GRADES**
 - a) There are two grades of licence for a Steward at Motocross events, National or Regional.
 - b) There is one grade of licence for a Referee at Supercross events, National.
3. **AGE LIMITS.** There is no upper age limit for Stewards/Referees at Motocross events. A Steward/Referee must be capable of inspecting the entire circuit without assistance prior to the event starting. (A Steward could use an ATV for this purpose in Motocross).

4.1.3 CHIEF TECHNICAL OFFICER

1. The Chief Technical Officer will be licensed by the Technical Panel to be in charge of the technical control at an event. The Technical Panel may restrict the disciplines of licence holders.
2. A regional Technical Officer will be trained in a centre or region but will be registered through the ACU at Rugby and may take charge of a meeting of below National status.

4.1.4 MEASURER

The licence is issued by the Technical Panel and may be restricted by discipline.

4.1.5 TIMEKEEPERS

Timekeepers will be required to renew and pay for their licence annually.

4.2 UNLICENCED OFFICIALS

Motocross, Supercross, Beachcross and Minibike Officials who do not require a Licence

Officials	Notes	Attendance at Seminar/Training Session
Incident Officer	1	None required
Secretary of the Meeting	2	Will receive training at events receive instruction from the Clerk of the Course
Technical Official		Will receive training via a Chief Technical Officer at meetings.
Club Stewards	3	May attend Regional or ACU HQ Seminars for information purposes
Chief Marshal		May receive training at ACU HQ or Regional Training Days
Marshal	4	May receive training at Regional Training Days and at meetings via the Chief Marshal.
Medical Officer	5	None required

1. All other Technical Officials, Race Day Officials (e.g. Secretary of the Meeting, Incident Officer, Club Stewards) and Marshals may be registered, free of any charge. All such Officials may or

- may not be required to attend a Seminar. Registration will be renewed annually. Registered Officials and Marshals will receive an appropriate form of identification from the ACU.
2. All assistant officials whose function is to be carried out at the immediate trackside must be at least 16 years of age.
 3. All assistant officials who are under 18 years of age must have obtained parental agreement to carry out the duty and the signing on signature must be countersigned by someone who is responsible for the official at the event.
 4. When using the services of minors (persons under 18 years of age) for any official duties at any event special attention must be given to any risks which may be associated with the duty, and to the previous experience of the official.

4.2.1 INCIDENT OFFICER

1. Will collate all information and documentation, and prepare reports relating to serious accidents and to all incidents involving Officials or Spectators.
2. A Deputy Clerk of the Course may undertake these duties. An Incident Officer may be nominated to attend a Clerk of the Course Seminar as part of their training.

4.2.2 SECRETARY OF THE MEETING

Will be responsible for all administration connected with the organisation of a meeting.

4.2.3 CLUB STEWARDS

Will together with the Chief Steward form the judicial authority over the running of the meeting.

4.2.4 MARSHAL

1. All Assistant Officials or Marshals whose function is to be carried out immediate trackside must be at least 16 years of age with the exception of Marshals who are in membership of a recognized corps of cadets/scouts/other discipline groups must be at least 14 years of age. All Marshals who are under 18 years of age must have obtained parental agreement to carry out the duty and the signing on signature must be countersigned by someone who is responsible for the official at the event.
2. Flag Marshals must be provided with a tabard/waistcoat clearly identifiable.

4.2.5 MEDICAL OFFICER

See medical section of ACU Handbook.

SECTION 5 SPECIFICATION OF MOTORCYCLE

(CATEGORY 1) All Motorcycles in group A1 (Solo), B1 (Sidecar) and G (Quad) shall comply with the National Sporting Code Appendix D and the following:

5.1 BRAKES

1. Motorcycles must be equipped with one efficient brake operating on each wheel and be operated independently from the driving position.
2. For B1 (Sidecar) motorcycles brakes are not required on the sidecar wheel.
3. For group G (Quad) motorcycles brakes must be capable of operating, as a minimum, to both rear wheels.

5.2 TYRES

1. There is no restriction as to the tyres that may be used other than as may be laid down in the Supplementary Regulations but chains and other non-skid devices will not be permitted.
2. Scoop or paddle (continuous radial rib) tyres and/or tyres with lugs having a height of more than 9.5mm are forbidden.

5.3 MUDGUARDS

Category A (Solo) and B (Sidecar) motorcycles must be fitted with two mudguards giving protection to the driver. The rear mudguard must cover 35 degrees of the upper rear wheel.

5.4 CLUTCH AND BRAKE LEVERS

1. Clutch and brake levers must be, in principal, ball ended, the diameter of the ball to be at least 12.5mm.
2. This ball can also be flattened but in any case the edges must be rounded.
3. These ball ends must be permanently fixed to form an integral part of the lever.

5.5 FOOTRESTS AND HANDLEBARS

The ends of the footrests must be rounded with a radius of not less than 8mm. The ends of the handlebars on all motorcycles shall be rounded or otherwise protected. Handlebars must be equipped with a protection pad on the cross bar. The handlebars without cross member must be equipped with a protection pad located in the middle of the handlebars, covering widely the handlebars clamps. For group G (Quad) motorcycles nerf bars must be fitted.

5.6 LAMPS

1. For motorcycles group A1 (Solo) and B1 (Sidecar) lamps, registration plates and licence holders must be removed.
2. For motorcycles group G (Quad) direction indicators and mirrors must be removed. Other glass or plastic lenses must be taped, padded with foam rubber, or equivalent, at least 25mm thick and taped again.

5.7 THROTTLE

All machines must be fitted with self-closing throttles.

5.8 EXHAUST PIPES

1. The end of the exhaust pipe or pipes must not project beyond any part of the vehicle or its bodywork.
2. Exhaust gasses must not be discharged so as to raise dust or foul the tyres or brakes or inconvenience a following driver.
3. A provision for the discharge of waste or surplus oil must be made so that it is collected and not spilt onto the circuit.
4. Breathers can be routed into air boxes or collector tanks.

5.9 RUNNING OF ENGINES

1. The running of engines is prohibited except during official practice, actual racing, sound testing and for a period not exceeding five minutes prior to the start of each race.
2. A breach of this regulation may involve disqualification from the meeting of the rider of the motorcycle concerned.

5.10 FUEL

For Fuel specifications please refer to Fuel Regulations section of the ACU Handbook.

5.11 IGNITION CUT-OUT

1. Motorcycles in group A1 (Solo) used in Motocross will be fitted with an engine cut-out button.
2. Motorcycles used in group B1 (Sidecar) will be fitted with an engine cut out button that must be operated by a non elastic string or cord (coil telephone wire is not permitted). The cord should be a maximum of 500mm. Any part of the cut-out that remains live when disconnected must be shrouded in order to prevent accidental contact with any part of the motorcycle.

- Motorcycles in group G (Quad) will be fitted with an engine cut out button that must be operated by a non elastic string or cord. Any part of the cut-out that remains live when disconnected must be shrouded in order to prevent accidental contact with any part of the motorcycle.

5.12 CHAIN GUARDS

- For motorcycles group A1 (Solo) and B1 (Sidecar) the manufacturer's original guards or parts of similar design must remain in place. However machines pre 2000 may be exempt from this rule. See national Sporting Code.
- For group G (Quad) motorcycles an adequate guard must be fitted to prevent any accidental contact with the primary chain or any part of the run not in contact with the sprocket. See National Sporting Code.

5.13 CONSTRUCTION

The use of titanium alloy nuts and bolts is allowed. But a dimension increase may be necessary when non-ferrous fasteners replace ferrous fasteners.

5.14 WHEELS

- For all groups wheels with six or less spokes must be guarded.
- For motorcycles group B1 (Sidecar)
 - The three wheels shall each be of at least 400mm (16") in diameter measured over the outside of the tyre.
 - The wheel track, or lateral distance between tracks, shall be no more than 1150mm.
- For motorcycles group G (Quad) the measurement from the front wheel to its following rear wheel must be equal.
- Titanium Spindles are not allowed.

5.15 ENGINES

For motorcycles group G (Quad)

- The engine must drive either or both rear wheels and must drive both rear wheels when competing against quads.
- The engine must be behind the front wheel(s) and central in front of a line between the rear wheel centres.

5.16 MISCELLANEOUS

- For motorcycles group B1 (Sidecar) a passenger must be carried in addition to the driver.
- Provision for the riders seat must be forward of a line between the rear wheel centres and above and/or behind the engine, to give the rider, when seated, full and safe control of the machine.
- For motorcycles group G (Quad) bumpers and nerf bars must have all corners with a radius of a minimum of 12.5mm.

SECTION 6 NUMBER PLATES

- Number plates will be a minimum of three in number on all machines and it is the rider's responsibility to ensure that the numbers are clearly visible.
- No metallic or reflective colours may be used in any circumstances.
- Plates and numbers must comply with the following requirements.
 - They must be made of a rigid material and solidly constructed.
 - The front plate should measure a minimum of 285mm × 235mm in size with a minimum of 50mm radius rounded corners.
 - The plates must be flat or slightly curved (not more than 25mm (1") from the true plane) and must not be otherwise bent or obscured in any way.
 - The front plate may be perforated but on no account may the numbers be perforated.

4. One plate must be carried facing forward and not more than 30 degrees from the vertical with one on each side of the machine.
5. Side number plates must be positioned above a horizontal line drawn through the rear spindle and behind a line drawn vertically at a minimum distance of 200mm behind the footrest. The size will be as accepted by the FIM.
6. The minimum dimensions of the numbers should be: height 140mm (5 $\frac{1}{2}$ "), width 80mm (3 $\frac{1}{8}$ "), width of stroke 25mm (1") and the space between any two figures 15mm ($\frac{5}{8}$ ").
7. The Clerk of the Course has the discretion to disqualify any rider not showing legible numbers or discounting any appeal resulting from illegible numbers.
8. For motorcycles group G (Quad) a third number plate must be fitted with a minimum size of 150mm x 150mm mounted behind the rider on the rear grab bar, and be in line with the machine reading left to right on both sides. The mounting bracket must not be higher than 150mm. Height of the number 100mm. Width of the number 80mm. Width of stroke 25mm. Space between two numbers 15mm.
9. The colours shall be as follows: The figures and background must be in a 'matt' (non-shiny) colour.

Front & Side Plates

Adult	Background Colour	Number Colour
100cc to 145cc 2 stroke/125cc – 250cc 4 stroke	Black	White
146cc – 650cc 2 Stroke/251cc – 650cc 4 stroke	White	Black
Sidecars	Yellow	Black
Quads	White	Black
Youth – Solo		
Automatic – 65cc Junior	Black	White
85cc Small Wheel (Intermediate)	Red	White
85cc Big Wheel (Senior)	Green	White
Open	Black	White
Youth – Quads		
50cc Standard	White	Black
50cc Modified	Blue	White
100cc Standard	White	Black
100cc Modified	Blue	White
100cc Geared	Red	White
125cc Geared	Yellow	Black
150cc 4 stroke	Red	White
250cc Stock	Yellow	Black
250cc Standard	White	Black
250cc Modified	Blue	White
250cc Open	Red	White
Minibike Adult		
50cc Pro Mini	Black	White
10"cc Pro Mini	Red	White
Midsize pro	White	Black
Superstock Midi	Blue	White
Midsize Clubman	Green	Black
Midsize Over 40	Black	Yellow
Mini Bike Youth		
50cc	Black	White
88cc	White	Black
111cc	Yellow	Black

Any other number plate or any marking on the motorcycle that might be confused with a number plate must be removed before the rider is allowed to start.

The only exception to the number plate regulations will be where special conditions apply to a National, Centre or Club Championship series and are explained in the Supplementary Regulations or conditions to that series.

Numbers for minibike racing must not exceed 2 digits, (i.e. 1-99)

6.10 NUMBER PLATE DIAGRAM

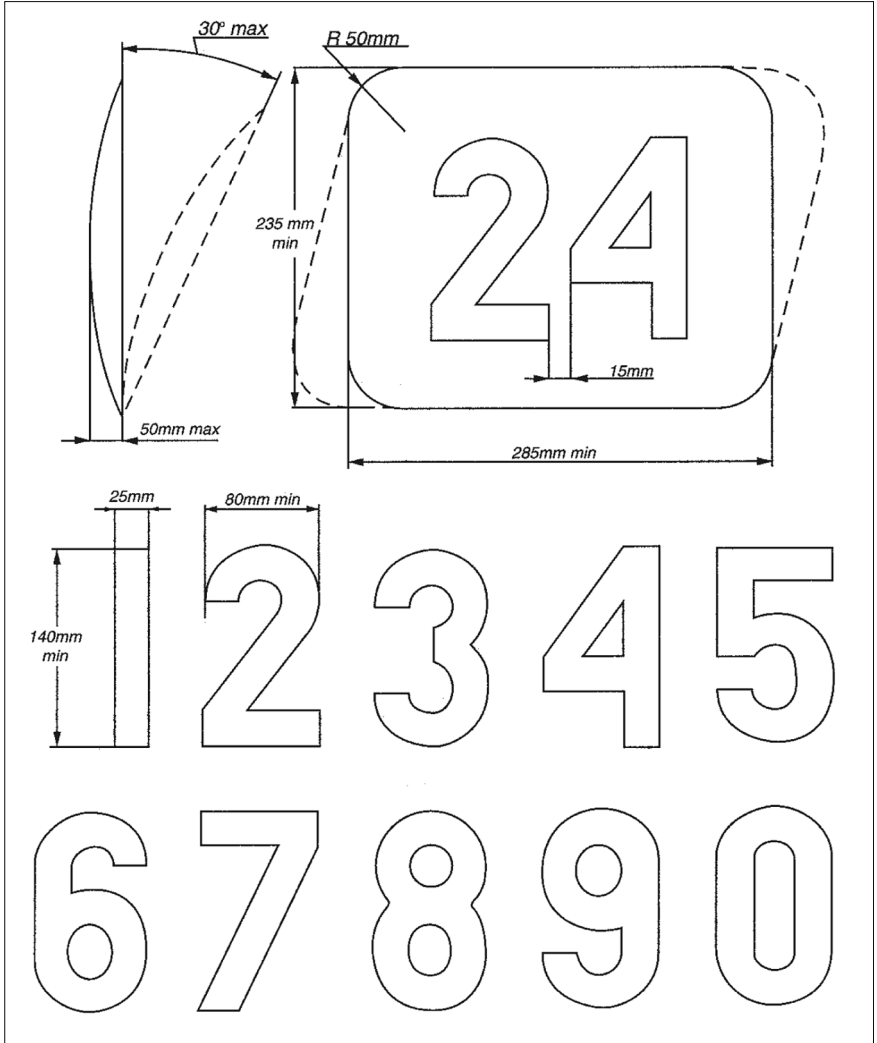

SECTION 7 TECHNICAL CONTROL

1. All motorcycles, helmets and protective clothing must be presented to the Technical Officer as requested, for examination before the start of any practice or at any time during the meeting as may be required by the Clerk of the Course to ensure that they comply with the requirements of the regulations.
2. Any machine damaged in an incident can be recalled by the Technical Officer for re-inspection before being ridden again at the meeting.
3. Any bike fitted with additional side panels or streamlining must have such panels removed when presented for a noise test.
4. Every motorcycle finishing in a race must, if so required, be submitted for final examination and any motorcycle may be retained by the promoters for such a period as may be reasonably necessary for its examination.
5. Where it may be necessary for promoters to verify any fact, this shall be carried out at the cost of the rider. If a rider refuses to release his machine to be measured by the officials of the meeting than this action will result in automatic disqualification from the event.
6. In the event of a protest against machine specification where an engine has to be stripped an additional fee of £250 for four stroke and £150 for two stroke machines MUST be submitted with the protest and protest fee. In the event of the protest being upheld the additional fee will be returned. If the protest is not upheld the additional fee will be awarded to the other party and will be the only costs payable.

7. Sound Level Control

Two tests will be in operation.

1. Static Test – For machines manufactured prior to 2010.

It is envisaged that this will operate until the end of 2015.

2. The FIM 2 Metre Max Test – For machines post 2011.

Solo

- For machines 2013 and onwards – maximum sound limit 112dB/A (+2 dB/A before each race, +3 dB/A after the race) tested using the 2 Metre Max method. Type 1 and Type 2 meters.
- For 2010–2012 machines – maximum sound limit 115 dB/A (+1 dB/A type 1 meters before each race, +2dB/A after the race) (Post race +1 dB/A for type 1 meters and +2 dB/A for type 2 meters) tested using the 2 Metre Max method.
- For machines pre 2010 – maximum limit 96 dB/A for 2 strokes and 94 dB/A for 4 strokes tested using the Static Test method. We envisage that this test will cease at the end of 2015 and the 2 Metre Max method will prevail.

Sidecars

Maximum sound limit for 2 stroke engines at 112 dB/A (+2 dB/A before the race, +3 dB/A after the race). For 4 stroke engines at 115 dB/A (+2 dB/A before the race, +3 dB/A after the race) tested using the 2 Meter Max method. A further review to be made at the end of 2015.

Quads

Maximum sound limit 112 dB/A (+2 dB/A type 1 & 2 meters before each race) (+3 dB/A type 1 & 2 meters after each race) tested using the 2 Metre Max method. A further review to be made at the end of 2015.

Procedure

All machines shall be sound tested using the 2 Metre Max method. Machines manufactured prior to 2010 that have a silencer that exceeds the maximum limit, the final acceptance will be defined by using the static test method and the limit will be according to the list.

96 dBA for 2 strokes and 94 dBA for 4 strokes. Operate according to the FIM method, that is, instead of using the machine piston stroke to calculate the test R.P.M., the fixed R.P.M. according to the capacity must be used, with the exception of over 500cc four strokes.

Up to 85cc

8,000 R.P.M.

Over 85cc up to 125cc

7,000 R.P.M.

Over 125cc up to 145cc	6,500 R.P.M.
Over 145cc up to 250cc	5,000 R.P.M.
Over 250cc up to 500cc	4,500 R.P.M.
Over 500cc	4,000 R.P.M.

There is no 2 stroke/4 stroke rev differential below 500cc. Due to the influence of temperatures on sound tests, all figures are correct at 20°C. For tests taken at temperatures below 10°C there will be a + 1 dBA tolerance. For tests below 0°C, a + 2 dBA tolerance.

There will be a + 2 dBA tolerance allowed for post race sound tests.

Machines Post 2011

The FIM 2 Metre Max Test Method will be enforced as previously detailed.

The maximum sound limit accepted: 115 dBA – + 1 dBA post race.

A sound level of 81 dBA at 100 metres during racing should be attained.

For 2015 other categories (ie. Twinshock, EVO Classic) the only test method will be 2 metre max unless stated otherwise in the Event Supplementary Regulations.

8. The Clerk of the Course may disqualify or penalise any rider of a machine which exceeds the maximum permitted sound level, or which in his opinion is deemed to be excessively noisy.
9. Random or spot checks may be made by ACU Sound Control Officials of the sound level of any machine taking part in any ACU meeting in addition to any routine checks at technical control.

SECTION 8 SAFETY

8.1 MEDICAL SERVICES

At all Motocross events, including official practice, qualified first aid personnel must be in attendance with full first aid equipment. Organisers must ensure sufficient medical services for the type of event remain in place until the event has completely finished.

For National and International Events a Medical Officer or Paramedic must be in attendance.

For all other status events A Medical Officer (MO) or a Paramedic (PM) or an IHCD Emergency Technician (EMT) or the Voluntary Aid Society (VAS) equivalent must be in attendance during official practice and racing.

The minimum requirement for the start of every event is two ambulances.

If one of the two ambulances has to leave the circuit then the minimum requirement for the event to continue is one ambulance and one Medical Officer (MO) or Paramedic (PM) or IHCD Emergency Technician (EMT) or the Voluntary Aid Society (VAS) equivalent, plus enough qualified first aid personnel to cover the course layout size and type of event subject to medical requirements shown below.

For clubs running events at Centre Restricted level and below and where there are less than 119 rider entries the minimum medical requirements are One ambulance – On the condition the ambulance is available at all times. Should the ambulance be required to support the treatment of, or transport an injured rider the meeting must stop until such time that the ambulance is available again. The ambulance should be accompanied by either a Medical officer (MO) a Paramedic (PM) or IHCD Emergency Technician or the VAS equivalent. Plus enough qualified first aid personnel to cover the course layout, size and type of event subject to medical requirements as shown in this Handbook.

1. If only one ambulance is listed as the minimum requirement at an event then organisers are reminded that if it has to leave the event then all practicing and racing must stop until its return or replacement. It is incumbent therefore on organisers of events to remember their commitment and duty of care to competitors in ensuring that sufficient medical services for the type of event, dictated by a risk assessment of the expected number of injuries, are in place prior to the start of practising and racing and remain in place until the event has completely finished.
2. Auxiliary vehicles, such as 4x4 with a stretcher, cannot replace an Ambulance but such vehicles might, at certain event sites, be used in addition to and as the final form of transportation to the Ambulance for the event.

Note A 4×4 vehicle can be an ambulance if registered with the DVLA as an ambulance.

3. If there is a requirement for first aid personnel to be present then they can be the two crew members of an Ambulance, assuming that one is present as a minimum requirement, but they must be available for all the practices and races. Such first aid personnel are an additional requirement to any doctors or paramedics required to be present at the meeting.
4. If there is a requirement for full first aid equipment, including a stretcher, then this can be the same equipment as that defined in the minimum equipment requirements for an Ambulance.
5. If the minimal medical cover required is for only one Doctor or only one Paramedic to be present then, if the only one available has to leave, for whatever reason, the practices or races must stop until their return or replacement.
6. If a Doctor is required at an event then they must be on site. It is not sufficient to have the name and address of a distant doctor, who would or might be available if required.
7. The nearest hospital, with an Accident & Emergency Department, must be notified in writing of the time, date and place of the meeting.
8. If a Doctor is involved in the treatment of competitors or spectators at an event, they should not normally be involved with drug or alcohol testing of competitors.
9. If a medical centre is available at a circuit or the site of an event then it should be fully operational and independently staffed. If deemed acceptable, an Ambulance or similar unit may act as a medical centre but if so, it must be additional to the minimum Ambulance requirements.
10. If no Medical officer or Paramedic is required at an event then at least one of the two Ambulance crew must be qualified as an IHCD Emergency Technician or the VAS equivalent, rather than just a first aid person.
11. If a competitor is involved in an incident involving potential injury, but is not, at the time, taken to Hospital for further treatment, then a relative, or a member of their crew, should be given a copy of the medical assessment or Ambulance report form completed by the event medical personnel following the incident.

8.2 CLOTHING

1. All competitors must wear a helmet. For information regarding helmets please refer to the helmet section within this Handbook.
2. Motorcycle clothing accessories (not helmets) sold as ‘protective’ to a supplier must display a “CE Mark” denoting compliance with a European Community Directive regarding Personal Protective Equipment.
3. Competitors are advised not to wear hand, face or body jewellery/piercings which could prove hazardous in the event of an accident.
4. The mouth should be kept clear of anything likely to cause blockage of the airway in the event of an incident, e.g. chewing gum. This includes removing false dentures.
5. It is not advised that bulky hard objects such as tools etc. are carried in pockets or on the person.
6. Goggles or visor of a non-splinterable type must be worn at the commencement of each race. Spectacles, if worn, must be non-splinterable.
7. The carrying of on board cameras on helmets is only permitted with prior approval of the Chief Technical Officer or Clerk of the course. The Camera used must automatically be released from its fixing in the event of a crash. The fixings should be of the flat “pad type” and not have any uneven or high elements to it. The camera unit itself should be non-splinterable.
8. It is advised that all riders and passengers should wear a body belt/kidney protector and wear protective armour giving protection to at least the chest and shoulders.
9. All riders and passengers are requested to wear identification discs around the neck or wrist during racing and practising. The disc should bear the wearer’s full name and date of birth.

10. It is the responsibility of the riders parent/guardian to ensure that all protective clothing is correctly fitting for youth competitors.

8.2.1 MOTOCROSS, SUPERCROSS AND BEACHCROSS

In all races and official practice complete protective clothing produced for motocross racing, knee length boots and gloves shall be worn by each rider and passenger. It is advised that motocross jerseys should provide protection against abrasion to the body and arms and that motocross jeans are padded at the hips and knees.

8.2.2 MINIBIKE

In all races and official practice complete protective clothing shall be worn by each rider. It is advised that Ankle boots should reach above the ankle ball. Ankle braces laced up properly and fit closely could be worn under the boot to increase stability. Jerseys should provide protection against abrasion to the body and arms. If short sleeved jerseys are worn then elbow pads must be worn to protect exposed skin. Trousers/shorts must provide protection to the knee, shin and hips. If Motocross style shorts are worn then they must cover the knee and must be used in conjunction with a knee, shin pad combination.

8.3 TRACK SAFETY

See ACU Course Guidelines booklet 2015.

8.4 FIRE EXTINGUISHERS

All competitors must have a 2kg (minimum) dry powder fire extinguisher available for immediate use. If a 'closed vehicle' is being used the extinguisher must be fitted adjacent to, or on the inside of the working door. In the case of a shared vehicle the other competitors extinguisher(s) should also be visible, or, the fitted extinguisher(s) must be of a proportionately larger capacity. All extinguishers must have a current certificate attached.

8.5 RIDING IN THE PADDOCK

Riding of machines in the paddock is strictly prohibited and warning signs should be erected. Machines should be pushed with the engine dead. Riding of machines at a slow pace can be permitted if designated lanes are provided. Machines must be pushed upon exiting from any point on these lanes. Riding to and from the Paddock – In exceptional circumstances or if permitted by the Clerk of the Course riders must not exceed first gear idle when travelling to and from the paddock area and must always wear a helmet.

8.6 TRACK ACCESS

Strictly no personnel, other than signed on officials, are permitted on the track while machinery is operating.

8.7 FLAG SIGNALS

The following flag signals will be used:

National Flag	This flag can be used for starting a race.
Red	All Riders must stop. Riders must not pass any red flag unless authorised or directed to do so and then proceed at a slow pace.
Black with the riders number clearly shown on a board	That rider to stop racing immediately and leave the track.
Yellow Motionless	Danger, take care. ride with caution.
Yellow Waved	Great Danger, prepare to stop, no overtaking. A significant reduction in speed must be seen, therefore jumps should not be attempted..
Marshals are only advised to wave their flags when riders are stopped on the course in a dangerous position or being attended to by officials or medical staff	
Green	Riders under starter's orders.
Blue	Warning you are about to be lapped.
Yellow with Black Cross	Last Lap./(either or) a two lap and then one lap board, clearly marked.
Chequered	Finish.
White with Green or Red Cross:	Medical attention required at that post.

N.B. 'Waved' shall mean a flag should be moved up and down through an arc of 45 degrees and not indiscriminately.

Only authorised officials are permitted to use these flags. Any rider who is judged to have taken unfair advantage whilst a yellow flag is displayed and waved, or ignored any other flag signal, may be disqualified. All of the above flags should measure not less than 750mm × 600mm.

SECTION 9 RACE MANAGEMENT

9.1 ENTRIES

A motorcycle sport entry form must be completed and signed by each entrant, rider or passenger. All riders, passengers and appointed persons responsible for minors must register arrival at an event by signing on at the event race office or designated area.

9.2 PRACTICE

1. Time must be put aside for the practice sessions and these must be defined in the Supplementary Regulations for the meeting.
2. Riders will commence practice under the instructions of the start officials and must join the circuit from the designated area.
3. The duration of practice will commence from the time when the first rider joins the circuit.
4. The waving of the chequered flag will indicate the end of practice.
5. For any race there must be a minimum period for practice on the actual course, the details of which must be stated in the Supplementary Regulations.

9.3 START POSITIONS

1. Start positions will be established according to the provisions of the Supplementary Regulations.

2. Where the organisers decide the grid positions will be by ballot this must be conducted by the competitors at the meeting.

9.4 SIGHTING LAP

Sighting Laps if held, shall be controlled under waved yellow flag conditions.

9.5 ELECTRONIC TIMEKEEPING

1. Only licensed ACU, MSA or equivalent Timekeepers can time a qualification practice where qualification to a final, a series of races, or start line positions is the determined outcome. Organisers must inform competitors if times are official or unofficial. The Chief Timekeeper should be stated in Supplementary Regulations, official programmes and on all results sheets provided.
2. Electronic lap scoring equipment does not require official timekeepers to operate a system but it is advised that manual lap scoring is carried out to support an electronic system.
3. If timed practice is used and identical times are recorded by more than 1 rider in the official qualifying practice session for the race the rider first setting such a time will receive the better starting position.
4. Transponders, if used, should be fitted to the machine as per the timekeepers or manufacturers instructions, it is the riders responsibility to ensure that the correct transponder is securely fitted, it is the riders responsibility if a transponder is lost from the machine during an event. Transponder Types – Mylaps Standard or Mylaps Flex MX Transponders. See manufacturer's instructions for charging transponders.

9.6 RACES

1. The race category and durations should be stipulated in the Supplementary Regulations.
2. In the event of a race being cancelled due to insufficient entries, the promoters reserve the right to offer the race time and prizes for a race of similar length for machines of another class or suitable category.

9.7 METHOD OF STARTING

The method of starting shall be stated in the Supplementary Regulations.

9.8 STARTER'S ORDERS

1. Riders are deemed to be under starter's orders when the first rider is called to the start line, signified by the raising of a green flag.
2. Riders in the 65cc or 85cc SW class will be allowed assistance from the start line officials if necessary, by raising their hand, to activate their launch control devices. This procedure is not deemed compulsory.
3. Any rider causing a start to be unnecessarily delayed in the opinion of the starter and/or the Clerk of the Course may be disqualified.
4. No persons will be allowed in the start area once riders have come under orders at the start line, except riders, passengers and authorised officials.
5. Once the riders are under starter's orders, the start procedure should not commence until the circuit is clear, signified by the lowering of the green flag.
6. If a 15 and 5 second board is used the following procedure will be followed.
 - The 15 second board will be displayed for a full 15 seconds
 - The 5 second board will be displayed for a full 5 seconds
 - The gate will drop between 5 and 10 seconds after the "5 seconds" sign is shown

9.9 FALSE STARTS

All false starts shall be indicated by the waving of a red flag, all riders will have to go back to the starting area and await announcements regarding the restart.

9.10 STOPPING A RACE

1. If a race is stopped before three laps have been completed, the race shall be re-run.
2. If a race is stopped under 50% of the race distance excluding any additional laps and over 3 laps completed the result will be taken at the end of the penultimate lap during which the signal to stop the race was given, a minimum of three laps must be shown on the completed race result. The race may be re-run at the discretion of the Clerk of the Course.
3. If a race is stopped after 50% of the race time has elapsed, excluding any additional laps, the result will be declared on the last completed lap.
4. In the event of a race being re-run the Clerk of the Course may disqualify any rider or riders who is/are the prime cause of the race initially being stopped.
5. If a race has to be stopped after the leader has completed 50% of the race distance, excluding any additional laps, rounded down to the nearest number of laps, it will be considered to have finished.
6. a) The order of classification shall be based upon the order of last crossing the finishing line prior to the showing of the red flag and only competitors who are racing at the showing of the red flag will be classified.
b) If a race has to be stopped after the leader(s) has taken the chequered flag they will be classified as having finished the race. The order of classification for those riders who have not taken the chequered flag shall be based upon the order of last crossing the finish control line prior to the showing of the red flag and only competitors who are racing at the showing of the red flag will be classified.
c) The Clerk of the Course may disqualify/penalize a rider from the results who has deemed to be the cause of the red flag incident.
7. For Adult National races to be classified as a finisher, riders must have completed 50% of the total laps completed by the race leader, or as per the Supplementary Regulations.
8. For Youth National races to be classified as a finisher, riders must have completed 50% of the total laps completed by the race leader, or as per the Supplementary Regulations.
9. Only the Clerk of the Course or his assigned assistants can stop a race, all courses must have sufficient assistants to ensure that when a race is stopped this decision is communicated to all of the riders as quickly as possible. A TCC can state how many assistants are required for a course and if radio communication is required.
10. For British Championship races please refer to the Supplementary Regulations.

9.11 FINISH OF RACE

1. The chequered flag will be displayed as the winner crosses the finish control line and will be kept flying thereafter until the last riders finish the lap.
2. No rider will be allowed to start a fresh lap after the chequered flag has been displayed.
3. Riders crossing the finish control line will be flagged off, their position being determined by the number of laps each has completed, those riders who complete a similar number of laps having their positions determined by the order in which they finish.
4. Only riders crossing the finish control line within the time limit laid down in the Supplementary Regulations will be declared as finishers.
5. For all Adult National races. To be classified as a finisher riders do not have to cross the finish control line, but riders must have completed 50% of the total laps completed by the race leader, or as per the Supplementary Regulations.
6. For all Youth National races. To be classified as a finisher riders do not have to cross the finish

control line but riders must have completed 50% of the total laps completed by the race leader, or as per the Supplementary Regulations.

9.12 RACE RESULTS

1. If the results are to be decided on points, the points allocation must be clearly defined in the Supplementary Regulations along with the method of deciding ties.
2. When a race has been completed the results will be based on the order in which a rider crossed the finish control line and the number of laps completed.
3. Should a tie occur on an overall result the highest position in the final leg will determine the final order.
4. It is the rider's responsibility to check the official results board/sheets for his finishing position and/or any penalties issued.
5. Series of Championship rounds – If the Championship Regulations allow for race results to be dropped then a rider who receives disqualifications during the year will not be allowed to consider/count them as one of his worst individual results etc. If a rider receives penalties during the year this could be considered/count as one of his worst individual results.

9.13 CHANGE OF MACHINE

A change of machine may be permitted provided the machine has been through Technical Control procedure. The same machine must be used throughout any one race.

9.14 CHANGE OF SIDECAR PASSENGER

1. The only reason to change a passenger is injury and only one change per meeting will be allowed.
2. The passenger must sign on, have the correct licence, and complete a sighting lap.
3. Application for a change must be in writing to the Clerk of the Course at least 30 minutes before the start of the race.
4. The final decision will be left with the Clerk of the Course.

9.15 OUTSIDE ASSISTANCE

1. If during a race a rider and/or passenger receives outside assistance other than that provided by the Organisers for the removal of himself or his machine from the course in the interests of safety, that rider may be disqualified.
2. Riders receiving signals from persons associated with them in prohibited areas may be disqualified.
3. The use of two way radios with a rider/passenger is prohibited.
4. Only riders who are competing in the race on the circuit are insured. Signed on riders who are not competing in the session on circuit are treated as spectators.

9.16 FOUL, UNFAIR OR DANGEROUS RIDING

The Clerk of the Course may penalise any rider who, in his opinion, is guilty of unfair, foul or dangerous riding.

9.17 COURSE CONDUCT

If, for any reason, a rider leaves the course, he must rejoin it as closely as possible at the point where he left the course without any outside assistance. He must not gain any advantage. If any advantage is obtained he may be penalised or disqualified from the results.

9.18 AWARDS

1. Awards of any description must be described in the Supplementary Regulations; the method of distribution must be announced before the completion of the event.

2. Awards for youth riders in youth events: Cash, gift vouchers, and goods are only permitted in the group A1 Open class and group G (Quad) 250cc Youth classes.

SECTION 10 GENERAL

10.1 INSTRUCTIONS TO RIDERS

Any Supplementary Regulations or instructions to riders subsequently issued, shall have the same force as these Standing Regulations but must in no way contradict these Standing Regulations.

10.2 CONDUCT

Riders, parents or associates failing to obey instructions given by officials of the meeting or deemed to have unjustifiably or maliciously jeopardised the efficient running of the meeting by not adhering to the Regulations, Supplementary Regulations or the protest procedure, may be disqualified from the meeting.

See also the National Sporting Code, Offences and Penalties.

10.3 PARENTAL RESPONSIBILITY

It is a parent's or guardian's responsibility to ensure that children stay within the confines of the event site and obey all instructions issued by the organiser.

10.4 DECLARATION

It is a condition of acceptance of entry that the promoters shall not be responsible for any damage to a motorcycle or its accessories whether by fire, accident or other causes, nor for the theft of a motorcycle or its accessories before, during and after the meeting.

10.5 COMPLIANCE WITH REGULATIONS

Every rider by entering or being entered or nominated, thereby acknowledges that he is bound by the National Sporting Code of the ACU and these Standing Regulations together with any Supplementary Regulations or Conditions and Final Instructions to be hereafter issued, to all of which he undertakes to submit and, moreover, renounces any right to have recourse to any arbitration or tribunal not provided for. All safety precautions for ACU Motocross events are available in a separate publication from the ACU.

10.6 DOGS AT OFF ROAD MOTORCYCLE EVENTS

Whilst dogs are not discouraged from attending Off Road Motorcycle Sport events, they are to be kept on a lead and under control at all times. Owners are responsible for ensuring their dog is kept under control and are responsible for clearing up any fouling that may occur.

SECTION 11 BEACHCROSS

11.1 SPECIFICATION OF MOTORCYCLE

All machines must comply with the appropriate specification applicable to the type, that is to say, Trial, Trail, Enduro, Motocross or ATVs. Paddle or scoop tyres are strictly forbidden.

11.2 LPG FUEL/DIESEL

Vehicles using LPG fuel must comply with the LPGA Code of practice 11. for auto gas installations June 2001, and will be subject to refuelling regulations, including a minimum 11kg fire extinguisher. Diesel fuel must be 'roadside pump' available.

11.3 CIRCUIT

Hazards should become progressively harder around the circuit so that large numbers of riders are

not stopped at the first hazard on the first lap. A number of flag marshals must be placed at each obstacle subject to the pre race risk assessment.

11.4 STARTER'S ORDERS

A rider shall be deemed to be under starter's orders when he collects his machine from the parc ferme/waiting zone.

11.5 FINISH OF A RACE

The chequered flag will be displayed as the winner crosses the finish control line and will be kept flying thereafter until the last rider finishes that lap. No rider will be allowed to start a fresh lap after the chequered flag has been displayed. Thereafter riders crossing the line will be flagged off, their position being determined by the number of laps each has completed, those riders who complete a similar number of laps having their positions determined by the order in which they finished within the time limit laid down in the Supplementary Regulations will be declared finishers. The organisers reserve the right to declare in the Supplementary Regulations the distance required to be declared a finisher.

11.6 DURATION OF A RACE

As specified in the Supplementary Regulations.

11.7 INTERRUPTION OF A RACE

The Clerk of the Course for reasons of safety may temporarily stop the event by the waiving of a red flag at any point on the circuit. The race will resume on the raising of the green flag by the Clerk of the Course.

11.8 DISQUALIFICATIONS

Any rider considered for disqualification may be allowed to complete the race and be disqualified, subject to protest and appeal procedures. If in the opinion of the Clerk of the Course the offence is undisputable the rider can be disqualified from the race immediately. The Clerk of the Course must write down the time, details of the offence and time of the disqualification to be given to the Stewards as soon as is possible.

SECTION 12 CROSS COUNTRY QUADS STANDING REGULATIONS

12.1 MEETINGS

12.1.1 DEFINITION

Cross Country events are controlled Group Start events which are a test of endurance and reliability. Competitors will be required to complete a number of laps within a time set by the organisers. The duration of events will be stated in the Supplementary Regulations.

12.1.2 PROCEDURE FOR STOPPING AN EVENT

Where it is deemed necessary to stop an event, only the Clerk of the Course or his assigned assistants can stop an event. All courses must have sufficient assistants to ensure that when a race is stopped this decision is communicated to all of the riders as quickly as possible.

12.2 ELIGIBILITY

12.2.1 ELIGIBILITY

All Adult riders must hold a current ACU or SACU licence and be a minimum age of 15 years. (Subject to the applicant holding an annual ATV licence issued by the ACU or SACU and having had 2 years previous racing experience, if an applicant cannot meet the above criteria then the minimum age will be 16 years).

Any rider from another FMN MUST produce a licence issued by their FMN together with start permission and proof of personal accident Insurance.

Day Licences. A one event Competition Licence grants the same benefits of an annual licence for the duration of the one event and is available for up to and including National Status.

Youth rider may compete in these events but must be a minimum of 7 years of age and a maximum of 16 years and is restricted to a maximum machine capacity of 250cc.

12.2.2 CAPACITY & RESTRICTIONS

Subject to the Supplementary Regulations any quad machine which complies with the Motocross Specifications as per the current ACU Handbook, may be allowed.

Adults +15 yrs

C1: Championship	For machines up to 550cc max 2 cylinder 2 stroke or up to 800cc 4 stroke max 1 cylinder
C2: Experts	For machines up to 550cc max 2 cylinder 2 stroke or up to 800cc 4 stroke max 1 cylinder
C3: Clubman	For machines up to 550cc max 2 cylinder 2 stroke or up to 800cc 4 stroke max 1 cylinder
C4: Utility & 4x4	For machines up to 550cc max 2 cylinder 2 stroke or up to 800cc 4 stroke max 1 cylinder

Youth

Y1: 250cc Stock	Yamaha 250cc Raptor Factory Delivered Spec + Optional Steering Damper, throttle & handlebar choice.	11–16 years
Y2: 250cc Standard	200cc 2 stroke. 250cc air-cooled. 4 stroke Production Quads built by the manufactures. There will be no modifications whatsoever allowed to engine, exhaust, carburetor, air box, clutch, electrics etc. Frame and engine must be by the original manufacturer. Engines must not have exceeded 200cc 2 stroke or 250cc 4 stroke at time of manufacture	11–16 years
Y3: 250cc Modified	200cc 2 stroke. 250cc air-cooled. 4 stroke Production Quads. Performance Modifications are allowed to the engine up to a maximum of 200cc 2 stroke or 250cc 4 stroke. Frame and engine must be by the original manufacturer. Engines must not have exceeded 200cc 2 stroke or 250cc 4 stroke at time of manufacture	12–16 years
Y4: 150cc Open	100cc 2 stroke, 150cc water cooled 4 stroke Quads. EATV, RM150 or Approved machines. Modifications are allowed to the engine up to a maximum of 100cc 2 stroke or 150cc 4 stroke. Engines must not have exceeded 100cc 2 stroke or 150cc 4 stroke at time of manufacture.	8–16 years
Y5: Beginner Production	70cc 2 stroke, 90cc 4 stroke Quads. Production machines built by the manufacturer. Engines must not have exceeded 70cc 2 stroke or 90cc 4 stroke at time of manufacture.	7–8 years

12.3 CLASS VARIATIONS

12.3.1 VARIATIONS

The Youth class must be run as a separate session from any Adult classes at the same event and must not be combined with any Adult classes at the same event. Youth capacity/Age/ability classes must be stated in the supplementary regulations.

12.4 LICENCES AND REGISTRATIONS (OFFICIALS)

As per Motocross Standing Regulations

12.5 SPECIFICATION OF A MOTORCYCLE

Category G (Quad) shall comply with the National Sporting Code appendix D and the following:

12.5.1 MOTORCYCLES

Subject to the Supplementary Regulations any Quad which complies with the Motocross Specifications as per the current ACU Handbook may be allowed.

12.5.2 TYRES

Tyre type is optional or as stated in the Supplementary Regulations.

12.6 NUMBER PLATES

All Quad machines must be fitted with a front & rear number plate of a minimum size of 150mm × 150mm with the rear mounted behind the rider on the rear grab bar, and be in line with the machine reading left to right on both sides. The mounting bracket must not be higher than 150mm. Height of the number 100mm. Width of the number 80mm. Width of stroke 25mm. Space between two numbers 15mm.

Adult Quads	Background Colour	Number Colour
C1: Championship	Red	White
C2: Experts	Green	White
C3: Clubman	Yellow	Black
C4: 4x4 Utility	White	Black
Youth – Quads		
Y1: 250cc Stock	Yellow	Black
Y2: 250cc Standard	White	Black
Y3: 250cc Modified	Blue	White
Y4: 150cc Open	Red	White
Y5: Beginner Production	Green	White

12.7 TECHNICAL CONTROL

- As per Motocross Standing Regulations
- Helmets** – Helmets bearing the ACU gold or silver stamp, in sound condition and properly fitted must be worn by all competitors. Please refer to the section in this Handbook titled ‘Helmets’ for other important information and conditions concerning European Community Exemption.
- Jewellery** – Competitors are advised not to wear hand, face or body jewellery which could prove hazardous in the event of an accident. The mouth should be kept clear of anything likely to cause a blockage of the airway in the event of an accident, e.g. chewing gum. This includes removing false dentures.
- Noise control** – Machines must be within the noise levels currently in force for that category of machine (see respective Standing Regulations).

12.8 SAFETY

12.8.1 MEDICAL SERVICES

As per Motocross Standing Regulations.

12.8.2 CLOTHING

As per current Motocross/Enduro Standing Regulations.

12.8.3 FIRE EXTINGUISHERS

All competitors with the exemption of those travelling to an event on the machine on which they are competing, must have a 2kg (minimum) dry powder fire extinguisher available for immediate use.

If a 'closed vehicle' is being used the extinguisher must be fitted adjacent to, or on the inside of the working door. In the case of a shared vehicle the other competitor's extinguisher(s) should also be visible, or, the fitted extinguisher(s) must be of a proportionately larger capacity.

12.9 RACE MANAGEMENT

12.9.1 COURSE

Must be 'off-road' and the minimum time should be set in the Supplementary Regulations. The organisers may split the event into 2 or more legs if desired but the minimum time for each leg must be set in the Supplementary Regulations. The ratio of competitors to course will be – 30 riders per km of course, e.g. 180 riders must have 6 km lap distance etc.

Any restrictions on the number of machines used by Team riders are to be stated in the Supplementary Regulations. All machines used are to be subject to Machine Examination.

For the Y5 Beginner production class organisers must ensure visual contact is applied at each rider at all times.

Special attention should be given to riders in this class for fatigue during the race.

The organisers must also ensure that each rider entered in this class is able to reasonably control their machine and should be identified by the wearing of a high visibility bib.

12.9.2 START

The start must be set out so that riders will start in groups which will be decided by the organisers e.g. capacity classes, ability classes etc. These groups will be defined in the Supplementary Regulations.

The number of riders in each group – which must not exceed 40 – and the start interval between groups – which must be no less than 30 SECONDS – will be decided by the organiser and due regard to course layout and the approval of the permit issuing authority. The organisers must ensure that the entire entry must be able to start and leave the start area before earlier riders start subsequent laps. In all circumstances there must be a dead engine start. This may limit the size of entry. Any rider who fails to start their machine at the allotted start time for their group will be credited for that original start time regardless of the actual time that they start. Start procedure will be stated in the Supplementary Regulations.

12.9.3 LAP SCORING AREA

An area must be designated which allows riders to pass through single file gates where their number will be recorded on the completion of every lap. Where there is more than one class the organiser may set alternative durations to suit the varying abilities. The organisers may stipulate that riders have to stop. The lap scoring area will be deemed as a "Blue Tape" area and marked as such.

12.9.4 FINISH

After the specified time/number of laps, the riders will be diverted through the lap scoring area and then from the course.

12.9.5 FINISHING ORDER

The winner overall and of any respective classes will be the riders who have achieved the closest number of laps to the duration set on the allotted time. Each riders start time will be taken as their respective groups start time, or individual start time as decided by the Organiser and their individual finish time will have been recorded.

12.9.6 FINISH OF RACE

1. The chequered flag will be displayed as the winner crosses the finish control line and will be kept flying thereafter until the last riders finish the lap.
2. No rider will be allowed to start a fresh lap after the chequered flag has been displayed.
3. Riders crossing the finish control line will be flagged off, their position being determined by the number of laps each has completed, those riders who complete a similar number of laps having their positions determined by the order in which they finish.
4. Only riders crossing the finish control line within the time limit laid down in the Supplementary Regulations will be declared as finishers.
5. For all Adult National races. To be classified as a finisher, riders do not have to cross the finish

control line, but riders must have completed 50% of the total laps completed by the race leader, or as per the Supplementary Regulations.

6. For all Youth National races. To be classified as a finisher, riders do not have to cross the finish control line but riders must have completed 50% of the total laps completed by the race leader, or as per the Supplementary Regulations.

12.9.7 TIES

Will be decided on the laps completed and the individual times of each rider.

12.9.8 CHECKS

The start/finish will be the only time check. There should be adequate marshals/route checks on the course to prevent course cutting.

12.9.9 MARSHALS

Organisers should place marshals at strategic points around the course to monitor safety and ensure control of event. Additional clearly identified Travelling Marshals can also be used to achieve this.

12.9.10 PUBLIC SPECTATOR AREAS

The Supplementary Regulations must announce the provision of clearly identified specific areas which must be used by all non competitors other than riders or officials. Warning notices must be placed at appropriate points around the course to prevent public access.

12.9.11 RESTRICTED SPEED (BLUE TAPE) AREAS

These areas MUST be established on the approach to the Time Control/Lap Scoring area and any Re-fuelling and works areas. Within 'BLUE TAPE' areas the rider must not exceed walking pace, under Penalty of exclusion. The Incident Officer/Clerk of the Course may also establish 'BLUE TAPE' areas at other parts of the course if required.

12.9.12 RE-FUELLING

A suitable and restricted area must be marked out adjacent to the course as a pit area. Access to this area must be restricted to marshals, riders and authorised helpers. The area should be manned by marshals and access only allowed to officials, competitors and authorised helpers. The Organiser MUST establish a fire point, clearly indicated and with the appropriate fire extinguishers present. Each rider shall ensure that his re-fuelling crew, have a fire extinguisher at the re-fuelling point as described in Regulation 3.13. 'No Smoking' signs should be displayed.

THE ENGINE MUST BE STOPPED AND THE RIDER OFF THE MACHINE DURING REFUELLING. NO SMOKING ALLOWED. REFUELLING MAY ONLY BE CARRIED OUT IN THE DESIGNATED AREA.

12.9.13 OUTSIDE ASSISTANCE

1. If during a race a rider and/or passenger receives outside assistance other than that provided by the Organisers for the removal of himself or his machine from the course in the interests of safety, that rider may be disqualified.
2. Riders receiving signals from persons associated with them in prohibited areas may be disqualified.
3. The use of two way radios with a rider/passenger is prohibited.

Assistance will only be allowed in the pit area, except when provided on the course by the organisers.

12.10 GENERAL

12.10.1 ENTRIES

A Motorcycle Sport Events Entry Form must be completed in every detail, and signed by each entrant, rider. (N.B. a requirement of signing and entry application form is that each signatory understands the National Sporting Code of the ACU, Standing Regulations, such Supplementary Regulations as have been issued for the event and such Final Instructions subsequently issued, and agrees to be bound by them).

Limitations of Entries. If entries are to be limited, the maximum number and method of limitation (i.e. in order of receipt, by ballot etc.) Will be stated in the Supplementary Regulations.

Child Protection. The point of contact for Child Protection issues will be the Secretary of the Meeting unless otherwise stated in the Supplementary Regulations.

12.10.2 ACCEPTANCE OR REFUSAL OF ENTRY

The Organiser must notify all riders of the position regarding their entry prior to the event. The method for notification will be stated in the Supplementary Regulations for the event.

12.10.3 PUBLIC WARNING

Notices must be displayed in accordance with the Safety Precautions section of the current ACU Handbook.

12.10.4 DOGS

Whilst dogs are not discouraged from attending Off Road Motorcycle Sport events, they are to be kept on a lead and under control at all times. Owners are responsible for ensuring their dog is kept under control and are responsible for clearing up any fouling that may occur.

12.10.5 COMPLIANCE WITH REGULATIONS

Every rider by entering or being entered or nominated, thereby acknowledges that he is bound by the National Sporting Code of the ACU and these Standing Regulations together with any Supplementary Regulations and Final Instructions to be hereafter issued, to all of which he undertakes to submit and moreover renounces any rights to have recourse to any arbitrations or tribunal not provided for.

SECTION 13 GRADING

13.1 ACU MOTOCROSS RIDERS EXPERT GRADING SCHEME (ADULT)

Expert status will be given to riders who appear on the Expert list compiled by the ACU Office

You can qualify for Expert Listing by the following means:

- Point scorer in an adult National Motocross Championship
- Registered Rider in the ACU British MX Championship – MX1/MX2
- Top 10 point scorer in the BYN Championship – Open class
- Selected by Centre Recorders based on Regional or Club Championships.
- Upgraded by the Motocross Committee

Riders may be removed from the list after two years if they have not scored any regional or national Championship points.

UPGRADING TO INTERNATIONAL

Once you have gained your expert status you are eligible to apply for an International Non Championship licence.

Sidecar Competitors – There will be no grading for sidecar competitors

Quad Riders – There will be no grading for quad riders

The Central Recorder for the Motocross Grading Scheme is:

Mrs S Goggin, ACU House, Wood Street, Rugby, Warwickshire, CV21 2YX. Tel: 01788 566404

SECTION 14 MOTOCROSS MOTORCYCLE

