

TRACK RACING

STANDING REGULATIONS

The Sporting Code and the Standing Regulations of the ACU together with the Supplementary Regulations will apply to all Grass Track Races.

The contents of this Document are Copyright and must not be reproduced without written consent from the Auto-Cycle Union Ltd. The various regulations contained herein become effective as at 1st January 2022. This publication supersedes previous editions.

ACU and The Auto-Cycle Union are trading names of The Auto-Cycle Union Limited. Registered under Company No. 00134679; Registered Office: ACU House, Wood Street, Rugby, Warwickshire CV21 2YX

The ACU aims to ensure that all people irrespective of their age, gender, disability, race, ethnic origin, creed, colour, social status or sexual orientation, have a genuine and equal opportunity to participate in motorcycle sport at levels in all roles. The ACU fully supports youth activity in all disciplines and through the ACU Academy, some of our young riders go on to become British, European and World Champions in their chosen sport.

All enquiries should be addressed to:

The Auto-Cycle Union Ltd.,
ACU House,
Wood Street,
Rugby,
CV21 2YX.

1	GENERAL	6
1.1	COMPLIANCE WITH REGULATIONS	6
1.2	ELIGIBILITY	6
1.3	NON-STARTERS/RESERVES/SUBSTITUTES	6
1.4	ALTERATIONS TO PROGRAMME	6
1.5	ABANDONMENT	6
1.6	BRITISH INDIVIDUAL GRASS TRACK CHAMPIONSHIPS	6
1.7	ADULT TRACK RACE RECORDINGS	7
1.8	YOUTH TRACK RACING RECORDINGS	7
1.9	CLERK OF THE COURSE	7
1.10	CONDUCT	7
2	PROCEDURES	8
2.1	DIRECTION OF RACING	8
2.2	RUNNING OF ENGINES	8
2.3	CONTROL OF EXHAUST SOUND LEVEL	8
2.4	ENGINES MEASUREMENT	8
2.5	ENVIRONMENTAL PROTECTION	8
2.6	TECHNICAL CONTROL	8
2.7	PRACTISING	9
2.8	ON TRACK STARTS	9
2.9	METHOD OF STARTING	9
2.10	STARTER'S ORDERS	9
2.11	DELAYING THE START	9
2.12	FALSE START	9
2.13	FLAG SIGNALS	9
2.14	FINISH OF RACE	10
2.15	FALSE FINISHES	10
2.16	STOPPING A RACE	10
2.17	STOPPAGE OF A RACE	10
2.18	RE-RUN RACES	10
2.19	LEAVING THE COURSE/CUTTING THE COURSE	10
2.20	RIDING IN THE PITS	10
2.21	RIDERS PRESENTATION LAP/WINNERS LAP OF HONOUR	10
2.22	OUTSIDE ASSISTANCE	10
2.23	FOUL, UNFAIR OR DANGEROUS RIDING	11
2.24	CHANGE OF MACHINE OR PASSENGER	11
2.25	TIES	11
2.26	MEDICAL CODE OF PRACTICE	11
2.27	DOGS/PETS	13
2.28	RIGHTS OF PROTEST	13
3	RIDERS	13
3.1	HELMETS	13
3.2	PROTECTIVE CLOTHING	14
3.3	JEWELLERY	14
3.4	FIRE EXTINGUISHERS	14
3.5	LICENCES	14
4	TECHNICAL	14
4.1	SPECIFICATION OF MOTORCYCLE	15
4.2	BRAKES	15
4.3	TYRES	15
4.4	MUDGUARDS AND WHEEL PROTECTION	15
4.5	WHEEL RIMS	16
4.6	ALL CONTROL LEVERS	16
4.7	FOOTRESTS AND HANDLEBARS	16
4.8	FRONT ENGINE PLATES SOLO – MACHINES	16

4.9	OPEN TRANSMISSION GUARDS	16
4.10	IGNITION CUT-OUTS	16
4.11	CARBURETTORS OR OTHER AIR INPUT CONTROL INSTRUMENTS	17
4.12	SUPERCHARGERS	17
4.13	CHASSIS CONSTRUCTION	17
4.14	EXHAUST SYSTEMS AND CONTROL OF EXHAUST SOUND LEVELS	17
4.15	SPECIFICATION OF THREE WHEELERS CATEGORY 1 (1000CC SIDECARS)	18
4.16	SPECIFICATION OF THREE WHEELER CATEGORY B1(C) 500CC	18
4.17	ADDITIONAL (OLD AND NEW) SIDECAR CLASSES	19
4.18	TRACTION CONTROL	19
4.19	FUEL	19
4.20	OIL CATCH TANKS	20
4.21	NUMBER PLATES	20
4.22	QUADS	21
4.23	CLASSIC PRE-75 SOLO GRASTRACK MACHINES	21
4.24	POST 1976 UPRIGHT SOLO GRASSTRACK MACHINES	21
4.25	FORMULA GRASS TRACK	22
4.26	GT 140	22
4.27	INTERNATIONAL 125CC FOUR STROKE SPECIFICATION	22
5	SAND/BEACH RACING	23
5.1	THREE WHEELER CATEGORY 1. GROUP B1 (A, B)	23
6	FLAT TRACK	23
6.1	DIRECTION OF RACING.	23
6.2	NO OF RIDERS.	23
6.3	PRACTICE.	23
6.4	TIME PENALTY.	23
6.5	STARTING INFRINGEMENT.	23
6.6	FLAGS AND SIGNALS.	23
7	FLAT TRACK TECHNICAL REGULATIONS	23
8	1000CC SIDECAR SPEEDWAY REGULATIONS	24
8.1	DEFINITION	24
8.2	DIMENSIONS	24
8.3	ENGINE	24
8.4	MINIMUM WEIGHT:	24
8.5	FUEL, OIL AND COOLANTS	24
8.6	EXHAUST SYSTEMS	24
8.7	WHEELS, RIMS AND TYRES	25
8.8	SIDECAR PLATFORMS	25
8.9	DIRT DEFLECTORS, MUDGUARDS, FAIRINGS	25
8.10	FRAME	26
8.11	THROTTLE CONTROLS AND IGNITION CUT OUTS	26
8.12	MEETING FORMAT AND REGULATIONS	26
9	YOUTH COMPETITOR REGULATIONS	26
9.1	ORGANISING PERMITS	26
9.2	JOINT YOUTH/ADULT EVENTS	26
9.3	ADVERTISING	26
9.4	RESPONSIBILITY FOR YOUTH ENTRANTS	26
9.5	AGE GROUPS, ENGINE CAPACITY AND NUMBER PLATES	26
9.6	UPGRADING	28
9.7	AWARDS	28
9.8	HOLDER OF A SPEEDWAY CONTRACT	28
9.9	CONDUCT	28
9.10	MINORITY CLASSES	28

9.11	STARTER'S ORDERS	28
9.12	CLOTHING	28
10	GRASS TRACK EVENTS HELD ON SPEEDWAY CIRCUITS	29
10.1	TO BE IMPLEMENTED WHERE ACU/ACU EVENTS/ACU CLUBS HOLD EVENTS ON SPEEDWAY TRACKS.	29
11	TRACK RACING OFFICIALS	29
11.1	QUALIFICATIONS AND CONDITIONS	29
11.2	TRACK RACING OFFICIALS WHO REQUIRE A LICENCE	29
11.3	TRACK RACING OFFICIALS WHO DO NOT REQUIRE A LICENCE	30

1 GENERAL

1.1 COMPLIANCE WITH REGULATIONS

Every rider (and parent/guardian for youth) entering or being entered acknowledges that he/she is bound by the ACU Sporting Code, these Track Racing Regulations, together with any Supplementary Regulations and Final Instructions thereafter issued to all of which they undertake to submit and moreover, renounce the right to have recourse to any arbitration or tribunal not provided for in the rules.

1.2 ELIGIBILITY

For National competitions, entrants, drivers and passengers must hold a current competition licence for International or National events issued by the ACU, or the Scottish ACU.

Organisers may allow licence holders from FMNs within FIM Europe to participate. Start permission from the relevant FMN must be submitted to the organiser and any additional third-party insurance must be obtained.

For all competitions of below National status, a current competition licence of the appropriate grade is required. Details of eligibility will be found in the Supplementary Regulations of the event.

Applicants for youth licences, please refer to the Youth Licence Regulations within this handbook.

The minimum age for an adult competitor is 16 years, but applications will be considered by the Track Racing Committee (TRC) for 15 year olds to ride in the 250cc class. The minimum age for 1000cc Sidecar drivers and passengers is 17 years. The minimum age for 500cc Right Hand Sidecar class is 15 years old for both drivers and passengers.

Any competitor over 70 years of age must have a medical examination.

1.3 NON-STARTERS/RESERVES/SUBSTITUTES

The place of any non-starter shall be taken by a RESERVE driver whose entry has been accepted, and in the order of priority as listed in the official programme of the competition.

A SUBSTITUTE driver may be nominated only by the ENTRANT being the holder of an Entrant's International or National competition licence.

Where a rider is his own entrant, no substitution will be permitted (see Sporting Code).

In the sidecar classes a change of passenger during a meeting is permitted if authorised by the Clerk of the Course and having completed a minimum of two laps practice within that class.

1.4 ALTERATIONS TO PROGRAMME

In the event of a race being cancelled due to insufficient entries, the organisers reserve the right to offer the race time and prizes for a race of similar length, for machines of another class or category.

1.5 ABANDONMENT

The organisers reserve the right, subject to the approval of the Clerk of the Course (or the Referee and Stewards when appointed) to cancel, postpone or abandon any event, or the competition itself, if circumstances should arise which in their opinion, renders such action necessary – such as the safety of the riders.

1.6 BRITISH INDIVIDUAL GRASS TRACK CHAMPIONSHIPS

It is a condition of the issue of a National competition licence that the competitors will not be granted authority to compete at home or overseas at any event which clashes with the qualifying rounds or the Final of an Individual Championship for which they have qualified or may be nominated for.

Competitors should also note the requirements for International selection through the appropriate Individual Championship. However, following a written request to the TRC, permission may be given for a rider to compete at a FIM EUROPE or FIM Championship event which conflicts with the date of an Individual Championship event within the UK.

1.7 ADULT TRACK RACE RECORDINGS

At all ACU Grass Track events, points will be allocated to competitors finishing in point scoring positions. Standings in the National Grading lists will be used to decide competitors for the 250cc and 350cc Solo, 500cc Sidecar and 1000cc Left Hand Sidecar British Championships.

The British Masters Qualifier Championship will not be awarded grading points.

For all Grass Track events, the following points will be awarded in each class:

1st = 6 points

2nd = 5 points

3rd = 4 points

4th = 3 points

5th = 2 points

6th = 1 point.

Points are allocated on the results of each class at each event. In classes where there is more than one Final, points will only be allocated on the results of the first Final.

Should an event be run where only one competitor is competing, gradings points will not be awarded.

Where a competitor rides in more than one class, they will score points for each class. These points are not transferrable between classes.

Points will not be allocated in an 'Unlimited' capacity or 'Open' classes, with exception of 'Upright' Solos and 'Pre 75' Solo classes. In these classes, 'Unlimited' and '500cc' results will be combined.

There will be no Grading List for 250cc or 350cc Upright or Pre 75 classes.

Results are declared by the Clerk of the Course. They are either decided by a one-race Final, or by point-scoring legs.

The conditions of results must be listed in the race programme. In the result of a tie, it is at the organising Club's discretion how ties are decided.

At the completion of an event, after confirmation of results from the lap scorers and Clerk of the Course, results will be sent by the Meeting Secretary to either the Track Racing Committee Secretary or the Track Racing Committee Grading Recorder (currently Gareth Bemister) for official classification within 48 hours of the conclusion of the meeting via email. Points will only be awarded if results are declared after no less than two heats per competitor. All National Grading lists will be published online throughout the season.

1.8 YOUTH TRACK RACING RECORDINGS

At all ACU Youth Grass Track events, points will be allocated to competitors in accordance with their finishing positions.

Points will be used to form the National Grading list for these four Youth classes:

(a) Auto-Cadet,

(b) Cadet,

(c) Juniors and

(d) Intermediates

Competitors who ride in more than one class will score points for each class, but points are not transferrable between classes.

All Youth competitors riding in an event will score points. However, competitors must complete in least one race to earn National grading points.

Points are allocated based on the number of competitors in the event. For example, when 5 riders compete, points will be allocated as follows:

1st = 5 points

2nd = 4 points

3rd = 3 points

4th = 2 points

5th = 1 point.

1.9 CLERK OF THE COURSE

A list of currently licenced National ACU Clerks of the Course is available from the ACU Head Office.

1.10 CONDUCT

All ACU licence holders are expected to conduct themselves in a professional manner. Any physical/verbal abuse will be subject to disciplinary action in accordance with NSC chapter 10/11.

2 PROCEDURES

2.1 DIRECTION OF RACING

Solos A, 500cc Sidecar B1(c), 1000cc Sidecars B1 (b), will race in an anti-clockwise direction. 1000cc Sidecar B1 (a) will race in a clockwise direction.

2.2 RUNNING OF ENGINES

The running of engines is prohibited except during official practicing and actual racing, and for a period not exceeding fifteen minutes prior to the start of official practice and five minutes prior to the start of each race. A breach of this regulation will involve disqualification from the meeting of the rider (and passenger where applicable) of the motorcycle concerned.

Engines must NOT be warmed up prior to Technical Inspection

2.3 CONTROL OF EXHAUST SOUND LEVEL

The Clerk of the Course may exclude any machine which exceeds the maximum permitted sound level, or which in his opinion is deemed to be excessively noisy.

The sound level will be controlled either by the fitment of an FIM homologated silencer or, in the absence of homologated silencers according to the FIM 2 Metre Max Method where the sound levels will not exceed 81dB(A) when measured at a distance of 100 metres.

For precise method of testing, please refer to the Sound Control Regulations within this Handbook.

Random or spot checks may be made by ACU Sound Control Officials of the sound level of any machine not fitted with an FIM homologated silencer taking part in any ACU meeting in addition to any routine checks at Technical Control.

Exhaust heatshields are recommended but not mandatory with the exception of the 500cc Sidecar class.

2.4 ENGINES MEASUREMENT

Where it becomes necessary for the ACU or an organiser to verify any fact relating to an engine capacity, it shall be carried out at the cost of the rider. Where an engine is measured, as the result of a protest, the protest must be submitted with the appropriate fee plus a deposit of £250.00 for a single cylinder engine and £500.00 for a multi-cylinder engine which can only be returned if the protest is upheld.

If the protest is unsuccessful then the deposit will be awarded to the person against whom the protest has been made and the protest fee will be sent to the ACU Benevolent Fund.

The Clerk of the Course shall judge as guilty anyone who refuses to present an engine for measurement.

The rider (and passenger where applicable) will be excluded from the results of the event and will be subject to disciplinary procedures. If engines are presented for measurement, but the Technical Official is unable to carry out the task at the event, the engines must be sealed for later measurement.

If seals are damaged or removed, the rider will be excluded from the results and fined. A sealed engine must be measured before the next round of that championship for which it has qualified, or within 28 days, whichever is the sooner.

2.5 ENVIRONMENTAL PROTECTION

Organisers must ensure that any waste oil collection points are positioned within suitable bunds.

The minimum technical data for an environmental mat is:

Solo motorcycles: minimum 160cm × 100cm

Sidecars: minimum 160cm × 200cm.

The ACU Environmental Code must be respected at all times.

2.6 TECHNICAL CONTROL

All motorcycles and protective clothing must be presented to the Technical Official for examination before the start of any practice, or at any time during the meeting as may be required by the Clerk of the Course or Senior Technical Official, to ensure continued compliance with the requirements of the regulations.

Spokes on all wheels must be accessible during technical control.

Any machine involved in an accident must be presented to Technical Control for re-inspection before being ridden again at the meeting.

Youth – protective clothing must be worn by competitors when presented for Technical Control. Engines should be cold when submitted for technical inspection.

2.7 PRACTISING

At all Grass Track meetings controlled practicing will be allowed on the course and each rider and passenger must complete at least two laps of practice to qualify for the event.

Practice laps must be recorded.

Solo: Youth and GT140cc should be run as separate practice sessions.

Practice Starts: practice starts are permitted provided they take place off the "racing line", unless stated otherwise in the Supplementary Regulations for the event.

2.8 ON TRACK STARTS

The Start/Finish line should be positioned at 50% of the length of the straight.

No more than eight Solos, six Sidecars or six quad machines are permitted at the start line.

The inner stanchion (post) of the 'On Track' start gate should be positioned approximately one metre from the inner edge of the track and should be covered with either straw bales or other suitable cushioning material – at least 60cm in width and two metres in height, towards the direction of racing.

The outer stanchion of the start gate should be positioned on the spectator side of the first catch fence and must be protected by straw bales or other suitable cushioning material.

Youth events: 'On Track' starting gates **ARE NOT** permitted at any youth only event. If a combined youth and adult event is being staged, then the organising club must supply an 'Off Track' starting gate for the youth competitors.

2.9 METHOD OF STARTING

The method of starting shall be stated in the Supplementary Regulations. Any rider whose machine touches the starting tapes once under starter's orders will be disqualified.

For National adult events a green light will be illuminated to indicate to riders that they are under Starter's Orders.

2.10 STARTER'S ORDERS

Only scheduled riders/passengers in the starting area or on a grid will be deemed to be under Starter's Orders, except Auto Cadet/Cadet Youth classes.

No other rider is subsequently permitted to start in a race. Machines must not move whilst under starter's orders.

2.11 DELAYING THE START

Any rider not prepared to start within two minutes after being called from the pit box will be disqualified from the race.

2.12 FALSE START

Any rider who in the opinion of the Clerk of the Course has caused a false start will be disqualified from that race.

2.13 FLAG SIGNALS

The following code of flag signals will be used where appropriate.

National flag: Start.

Yellow: Accident, slow down, driver must be prepared to stop. OVERTAKING STRICTLY PROHIBITED. Any rider judged to have taken unfair advantage by racing or attempting to overtake within the area controlled by the yellow flags will be considered guilty of unfair and/or dangerous driving and will be disqualified.

Red: Immediate STOP all drivers – return to the pits at a walking pace or as directed by the **Marshals**.

Green: Course clear.

Yellow with Black Diagonal Cross: Start of last lap.

Chequered Black and White: Finish.

Any additional flag signals will be stated in the Supplementary Regulations. Only authorised Officials are permitted to use these flags.

All the above flags should measure not less than 750mm × 600mm.

2.14 FINISH OF RACE

The chequered flag will be displayed as the winner crosses the finishing line and will be displayed until the last rider finishes the lap.

No rider will be allowed to start a new lap after the chequered flag has been displayed. Thereafter riders crossing the line will be flagged off, their position being determined by the number of laps each has completed.

To be classified as a finisher a rider must complete $\frac{3}{4}$ of a four lap race or $\frac{2}{3}$ of a six lap race within threeminutes of the winner crossing the finish line.

A competitor who has started in a Final but not completed race distance will be placed according to the number of laps completed, without the requirement to complete a minimum number of laps.

2.15 FALSE FINISHES

When a race has been indicated as finished by the display of the chequered flag before the required number of laps has been completed by the leading rider, the race must be declared null and void and re-run unless the leading rider had completed 75% of the scheduled number of laps, in which case the result will stand.

If the chequered flag has not been shown after the completion of the scheduled number of laps, the chequered flag shall be considered to have been shown at the completion of the scheduled number of laps.

2.16 STOPPING A RACE

- a) If an incident occurred on the race start straight or the first corner, which the Clerk of the Course determines will unfairly affect the outcome of the race he may, at his sole discretion, declare an unsatisfactory start, stop the race and allow all riders back into the re-run.
- b) If an accident has occurred and in the opinion of the Clerk of the Course it would be dangerous for the race to continue, he will order the race to be stopped and may order it to be re-run. The Clerk of the Course will exclude the rider(s) who he deems to be the primary cause of the race being stopped.

2.17 STOPPAGE OF A RACE

If a race is stopped before the race leader has completed $\frac{3}{4}$ of a four lap race, or $\frac{2}{3}$ of a three or six lap race, the race shall be re-run. If the race leader has completed the above race distances, ($\frac{3}{4}$ of four lap race or $\frac{2}{3}$ of a three or six lap race), before the race is stopped, the results can be declared at the discretion of the Clerk of the Course.

2.18 RE-RUN RACES

In the event of a race being re-run, the Clerk of the Course may permit any rider who has fallen either as a result of his having been fouled or because he had deliberately 'laid down' his motorcycle or has left the course in the interest of safety, to take part in the re-run.

Any rider having been the primary cause of the stoppage, or not proceeding under mechanical power at the time of the stoppage, will not be eligible to take part in the re-run.

2.19 LEAVING THE COURSE/CUTTING THE COURSE

Any competitor(s) whose motorcycle crosses the defined edges of the track markers/white line – with any wheel – will be disqualified unless, in the opinion of the Clerk of the Course, the action was taken in the interest of safety for other competitors, or the competitor involved was forced 'off course' due to the actions of another competitor.

2.20 RIDING IN THE PITS

The riding of motorcycles (including electric / pit bikes) in the designated pit area **is strictly prohibited**. Where possible an area protected by a safety fence shall be provided for competitors to start their motorcycles.

2.21 RIDERS PRESENTATION LAP/WINNERS LAP OF HONOUR

No unauthorised passengers (children, wives/partners etc.) are allowed to ride on a competitor's motorcycle at any time during the event.

2.22 OUTSIDE ASSISTANCE

If, during a race, a rider receives outside assistance, other than that provided by the organisers for the removal of himself or his machine from the course in the interests of safety, he will be excluded.

2.23 FOUL, UNFAIR OR DANGEROUS RIDING

The Clerk of the Course may discipline any rider who, in his opinion is guilty of unfair, foul or dangerous riding in accordance with 10.03.3.3 of the National Sporting Code of the ACU.

2.24 CHANGE OF MACHINE OR PASSENGER

A change of machine and/or passenger within a particular capacity class may be permitted at any stage of an event (including the re-run of any races) subject to the approval of the Clerk of the Course, providing that:

- (a) The machine has been passed by the Technical Official.
- (b) The passenger has an appropriate licence, has signed on, and has taken part in the Sidecar practice.

2.25 TIES

(Required for ACU Championship and National events, recommended for other events – if an alternative method is to be used, it must be included in Supplementary Regulations)

Intermediate/Semi Final Standings

- a) Count back
- b) Best position in the last heat that the riders met
- c) A ballot in the presence of a Steward
- d) Finals where points are carried forward
- e) Where riders tie on points after the Final, the best place in that Final will decide the overall result.

2.26 MEDICAL CODE OF PRACTICE

Track Racing is potentially dangerous; therefore, care regarding the quality of medical facilities, medical personnel and the fitness of riders is necessary; hence this Code sets out the minimum requirements necessary.

Note: Local hospital authorities must be advised prior to the event of the time and date of the meeting.

The Competitors

Every competitor taking part in a Grass Track event must be medically fit, not under the influence of alcohol or prohibited drugs, and certifies this at the time of Signing-On at a meeting or permitted training session.

Competitors, having signed-on, may be required to undergo a medical examination to confirm both their physical and mental fitness. A failure or refusal to undergo an examination will result in immediate disqualification from the meeting or permitted training session.

Where a competitor is withdrawn from a meeting due to injury, all instructions given by the Medical Officer should be noted and adhered to.

Concussion/suspected concussion

If a competitor is involved in an incident which results in him/her being diagnosed by the Medical Officer/Paramedic as suffering from concussion or suspected concussion, the competitor is not permitted to participate any further in that event.

Organisers are to notify ACU Head Office as soon as possible of any concussion/suspected concussion injuries and then will subsequently:

- a) Place the competitor on the ACU Stop List
- b) Inform organisers of forthcoming events that the competitor has suffered a concussion or suspected concussion injury and is therefore placed on the ACU Stop List
- c) Inform the competitor that s/he needs to see a Doctor and obtain a letter/Doctor's certificate which confirms s/he is fit to resume competitive racing/participate in a practice/test session.

The recovery time for anyone diagnosed with concussion or suspected concussion is as follows:

- a) Over 20 years: Excluded immediately and suspended for a period of nine days.
- b) 16–19 years: Excluded immediately and suspended for a period of twelve days.
- c) 15 and under: Excluded immediately and suspended for a period of twenty three days.

The competitor is not permitted to ride during the obligatory suspended periods outlined above and then only once s/he is in possession of a Doctor's certificate/letter after the suspended period has expired.

If a competitor has been injured on a Saturday and is suffering from concussion or suspected concussion, and the organiser is aware that the competitor was intending to ride or is scheduled to ride somewhere else the next day, the organiser will inform the organiser of the event being held the next day, so they are aware of the competitor's injuries and as such s/he is prevented from participating in that event.

Facilities

The minimum personnel and facilities required at ALL Grass Track events (below National status) are:

- a) One qualified Medical Officer (MO) e.g. a Doctor, OR a Paramedic (PM) OR an IHCD Emergency Technician (EMT) who must be in attendance during both official practice and racing
- b) One Ambulance with a driver and attendant,
- c) One Medical Treatment Facility
- d) Four qualified First Aid personnel complete with full First Aid equipment, including a stretcher A second ambulance is strongly recommended but if not, as a minimum, an auxiliary vehicle with a stretcher must also be available on the course during both official practicing and racing.

For events of NATIONAL status and above arrangements must also be made for TWO Doctors or TWO Paramedics, with appropriate equipment for racing, to be in attendance during official practice and racing with TWO(class C) ambulances being available.

For further details, please refer to Medical Services Document.

The Medical Officer

The Medical Officer can be either a Doctor or a Paramedic. Nevertheless, where a Doctor is present, s/he will be the Chief Medical Officer, and in the case of two or more Paramedics being in attendance, the one that signs the Injury Report Form assumes the role of Chief Medical Officer.

A Doctor must have Medical Malpractice Cover appropriate for pre-hospital immediate care, (NHS Crown Indemnity is not applicable) and must not be subject to working in a GMC Approved Practice Setting (APS).

A Paramedic must hold appropriate Personal Medical Malpractice Insurance cover.

All Paramedics must be registered with the Health Professional Council. Names of Paramedics should be obtained by an organiser prior to the event taking place and then checked on the following HPC website:

<http://www.hcpc-uk.org>.

The Chief Medical Officer's responsibilities under these Regulations are to:

- a) Carry out medical examinations of any competitor when specifically requested to do so by the Meeting Steward and or Clerk of Course and in all cases following a track incident.
- b) Complete the appropriate documents as required under ACU Regulations.
- c) Ensure a full complement of personnel and equipment as detailed in these Regulations is available at all times during the Meeting, signing the Injury Report Form to confirm the fact and also that all personnel and equipment conforms to the ACU and other legal requirements.
- d) Ensure adequate arrangements have been made and are maintained for dealing with any casualties and be quickly accessible to the Clerk of Course and be readily available to deal with all medical emergencies.
- e) Inform the Clerk of Course if at any time during the meeting any of the medical requirements are not being met.
- f) Order that racing and/or training be suspended, when insufficient medical cover is available (e.g. following an accident or when the Ambulance, any of the required items of equipment, medical gasses or drugs etc. is not available).
- g) Ensure the availability of and administer any Prescription Only Medicines (POM) or Controlled Drugs (CD) that are appropriate. NB. A Paramedic who has access to drugs on licence from his employing authority may also administer them in accordance with his employing authority's protocols.
- h) Have available resuscitation drugs conforming to Resuscitation Council guidelines and a supply of parenteral and oral analgesics
- i) Ensure that the medical team and First Aiders are familiar with ALL varieties of clothing and equipment worn by competitors/passengers and in the safe procedures for their removal.

Medical Treatment Facility

The Medical Treatment facility may be a second fully equipped Ambulance or a designated Medical Room/tent, with good access, that is well lit, dry, windproof and heated with curtains or similar at all windows, has a chair/couch or similar, a supply of basic medical equipment and facilities for hand washing with hot and cold water.

Note: If this is a second Ambulance, appropriately qualified persons must be available to supervise a casualty.

Doctors, Paramedics and First Aid personnel must be in attendance 30 minutes prior to the official practice or start time (whichever is the earliest), wearing appropriate outer clothing that clearly shows their professional designation (front and back) and have personal malpractice indemnity insurance cover or similar provided by their governing body or employing authority (excludes NHS Crown Indemnity).

All members of the medical team (one of whom must have a mobile telephone in working order) must be immediately available to and under the direct control of the event's Chief Medical Officer, who has overall responsibility for all medical and First Aid matters.

Ambulances

Ambulances must be legally road-worthy, taxed, insured and registered as an ambulance with UK DVLA and where applicable, with the Care Quality Commission.

The primary ambulance at a meeting must be appropriate for and insured for emergency casualty transportation, have radio communications together with visible and audio signals.

It should be equipped as a resuscitation centre and carry two stretchers; one of which must be an ambulance cot (the second can be a scoop type or similar).

Ambulances must incorporate an oxygen supply system that can deliver oxygen at the rate of 10+litres/minute for

60+ minutes, a portable oxygen supply system that can deliver oxygen at the rate of 10+litres/minute for 20+ minutes with oxygen therapy masks capable of delivering high concentrations of oxygen.

Apparatus for:

- a) Automatic or manual ventilation, suction, and intravenous infusion (plus infusion fluids),
- b) Equipment to immobilise limbs and vertebral column
- c) Equipment and fluids for irrigation and toilet of eyes and wounds
- d) First Aid medicaments and materials
- e) ECG Monitor, defibrillator, stethoscope
- f) Inhalational analgesia (nitrous oxide/oxygen mixture) and equipment for its administration
- g) Instruments for haemostasis, equipment for dealing with burns
- h) Apparatus for securing an emergency surgical airway (e.g. cricothyroidotomy)
- i) Equipment for thoracic drainage/de-compression
- j) Sphygmomanometer
- k) Equipment to remove clothing and helmets
- l) Ice or other appropriate means for cooling injuries

The crew of the primary ambulance must consist of a driver, trained and qualified to drive under blue light response conditions and be accompanied by a competent attendant who is capable of giving emergency treatment, both of whom should remain with the vehicle at all times when the ambulance is utilised.

For definitions of Doctor, Paramedic, Ambulance and First Aid personnel please refer to the Medical Services section within this Handbook. Paramedics must be registered with the Health Professional Council.

Note: Be aware that some Paramedics and St Johns Ambulance teams may not be able to carry morphine

2.27 DOGS/PETS

Whilst dogs and other pets are not discouraged from attending Off Road motorcycle sport events, they are to be kept on a lead and under control at all times.

Owners are responsible for ensuring that any dog is kept under control and are responsible for clearing up any fouling that may occur.

2.28 RIGHTS OF PROTEST

No protest can be accepted against decisions made by the Clerk of Course or referee where appointed, Chief Technical Steward against matters that are considered a Statement of Fact. Specifically, these include:

- a) A ruling on a heat result
- b) A ruling on a racing incident (such as articles 2.11, 2.12, 2.16, 2.21, 2.22, 2.23)
- c) A ruling on a Technical Matter

At all meetings a separate, private enclosed area is to be provided away from the public area in order to deal with any protests that may arise.

3 RIDERS

3.1 HELMETS

Helmets approved by the ACU bearing the current ACU approval stamp and being in sound condition and properly fitted must be worn by all riders and passengers while practicing and racing.

Overseas competitors may use helmets as approved by their own FMN or FIM. Cameras mounted on helmets will not be permitted to be used in Track Racing. For further information regarding helmets please refer to the Helmet section of this handbook.

3.2 PROTECTIVE CLOTHING

In all races and official practice outer clothing made of leather or a substitute, substantially padded at the shoulders, elbows, hips and knees, and leather or suitable substitute material gloves, must be worn by both riders and passengers.

Racing suits should be one piece or effectively joined when worn to form one piece. Any other racing suits must meet the standards required for leathers.

Where non-leather materials are used, they should have the following characteristics equivalent to leather:

- a) Fire retardant ability
- b) Resistance to abrasion
- c) Coefficient of friction against track surfaces
- d) Perspiration absorbing ability
- e) Be nontoxic and non-allergic
- f) Fabric must not melt

The clothing manufacturer is responsible for ensuring that the products and materials that carry his name conform to these rules.

Kevlar suits are approved ONLY if worn with padding or a padded under suit. This under suit can be either one or two piece.

Motocross race wear (e.g. separate top/ shirt and trousers) is permitted as long as suitable body armour or a protective under suit is worn.

The body armour or under suit must offer suitable protection against abrasion to the body, with padding provided to protect the shoulders, elbows, hips and knees.

Footwear: The minimum requirements for protective footwear for riders is calf length boots and for passengers leather ankle boots (minimum height 200mm).

Goggles: Goggles, and spectacles if worn, shall be of a non-shatter proof material.

Rigid 'Tear Offs' must have rounded corners to avoid causing injury to others when discarded.

Back Protectors: competitors in all classes are required to wear commercially manufactured back protection during both practice and racing.

Youth Protective clothing requirements:

Youth protective clothing should comply to the same standards as those required for adults including the wearing of back protectors.

3.3 JEWELLERY

Competitors are advised not to wear hand, face or body jewellery/piercings which could prove hazardous in the event of an accident.

The mouth should be kept clear of anything likely to cause a blockage of the airway in the event of an incident, e.g. chewing gum. This includes removing dentures.

3.4 FIRE EXTINGUISHERS

All competitors must have a 2kg (minimum) dry powder fire extinguisher available for immediate use.

If a 'closed vehicle' is being used the extinguisher must be fitted adjacent to, or on the inside of the working door.

In the case of a shared vehicle the other competitor's extinguisher(s) should also be visible, or, the fitted extinguisher(s) must be of a proportionately larger capacity.

Competitors must ensure that their 'vehicle mounted' fire extinguisher is serviced in accordance with the manufacturer's recommendations.

3.5 LICENCES

- a) FIM and FIM EUROPE Championship Licences – the Track Racing Committee will confirm the competitors who qualified and are eligible for these licences. The holders will be automatically entitled to hold an International Non-Championship Licence.
- b) International Non-Championship Licence – to qualify for an FIM Non-Championship licence, a competitor must finish in the top twenty (Solo) or top ten (Sidecar) in the appropriate British Masters or National Championship. The FIM Non-Championship licence is valid for a period of two years commencing on the 1st January following the date of qualification.
The Track Racing Committee reserve the right to issue this licence to competitors in exceptional circumstances.
- c) Licence Upgrading – to upgrade to a National licence, competitors must obtain signatures from the relevant Clerk of the Course to demonstrate that they have finished in SIX finals at lower level events.
- d) Sidecar riders and passengers wishing to upgrade to a National licence must obtain signatures from the relevant Clerk of the Course to demonstrate they have finished in six finals at lower level events in the same category that they are seeking a National licence for.
- e) Lapsed Licences – any competitor wishing to renew a licence which requires qualification, and the licence has been expired for more than THREE years will be issued with a Restricted licence.

4 TECHNICAL

Each rider is responsible for ensuring that his motorcycle conforms to the Technical Regulations.

Refusal to allow the examination of the motorcycle, or any parts of the motorcycle, by the appointed Technical Steward at any time during the meeting, and for 30 minutes after the Final race, shall be deemed to be an offence which will be reported to the Clerk of the Course and may result in the disqualification of the rider and machine from the race or meeting.

4.1 SPECIFICATION OF MOTORCYCLE

Motorcycles of Solo Category 1, Group A1, Sidecar Category 1, Group B1 (a, b, c) must comply with the following discipline requirements in addition to those of the National Sporting Code Appendix D.

Machines originally designed for Enduro, Motocross, and Trials competitions (as defined in the respective regulations) are permitted in race meetings but may not be used in the same races as Track Racing motorcycles, but may be included on the same permit.

4.2 BRAKES

Motorcycles in Category A(1) and A(2) (Solos) must comply with the following:

- 140cc, 250cc, 350cc and 500cc Track Racing motorcycles used in adult competitions must not be fitted with brakes or decompressors.
- All other motorcycles used in adult competitions to be fitted with at least one effective brake. Motorcycles in Category 1 Group B (a, b) must be equipped with at least one effective brake operating on the motorcycle wheels.

Motorcycles in Category B1(C):

- Brakes are not permitted on 500cc Sidecar motorcycles.

For Youth competitions,

- All machines must be fitted with an effective brake, with the exception, machines used in the International 125cc and 250cc four stroke class competitions where brakes are not allowed.

Machines without brakes CANNOT COMPETE in the same races as machines with brakes.

4.3 TYRES

Except for the prohibited use of tractor pattern tread tyres there is no restriction as to the type of tyres which may be used for Solo motorcycles, other than as may be laid down in the Supplementary Regulations.

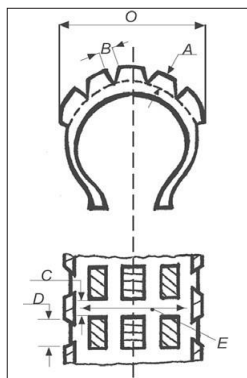

The tread depth and spacing of tyres fitted to the driven wheel of Groups B (a, b) must not exceed the dimensions specified for trials tyres refer to diagram.

The overall width, measured at wheel spindle height must not exceed 150mm.

Tread depth (A) must not exceed 13mm. All tread blocks in the same circumference must be of the same depth. The space between the tread blocks (B) must not exceed 10mm across the tyre or 13mm in a circumferential direction (C).

The space between the shoulder blocks (D) must not exceed 22mm. The space across the tread (E) must not extend completely across the tyre measured at right angles to the tyre wall unless broken by a block.

All main tread blocks must in principle be parallel with or at right angles to the tyre axis.

(The tyre must have the same appearance if reversed and conform in principle with these diagrams).

The tread pattern of the tyre must not be modified.

4.4 MUDGUARDS AND WHEEL PROTECTION

Category 1, Group A and B motorcycles must be fitted with two mudguards giving protection to the driver. The rear mudguard must extend laterally beyond the tyre and cover at least 35 degrees of the upper front quadrant of the rear wheel and must extend to 5 degrees or more behind a vertical line running through the rear wheel spindle and must extend to the full width of the tyre.

The Clerk of the Course may permit the removal of the front mudguard if conditions make this desirable.

If cast or welded wheels are used for all types of Track Racing a protection must be provided by enclosing the spokes with solid discs.

The Sidecar wheel mudguard must extend to the full width of the tyre.

Dirt Deflectors (DD) – The 'flap' must retain its original shape. Any 'flap' that is distorted, holed, worn through, cut or dismembered must be replaced prior to racing.

The DD 'flap' must remain effective under all track surface and wind conditions.

The DD 'flap' must be shaped and positioned in such a way that the distance of the upper 'flap' edge to the complete tyre tread width.

The opposite lower edge shall be 35mm maximum (+/- 5mm) from the track surface over an equal distance.

All of the measurements are taken with the motorcycle in a vertical position, with the tyres normally inflated but without a rider.

The mechanism must maintain constant function of the pivot arrangement and be able to return the DD 'flap' to its normal operating position with minimal delay.

To measure the tension provided by the mechanism of the DD, a vertical balance shall be used to measure an equivalent minimum pre-load of 6kg for 1000cc Sidecars.

The vertical balance must be attached to the outer edge of the DD holder in line with the centre of the tyre.

If 'Huggers' are fitted to protect the rear wheel of Solo machines competing at ACU domestic events, they must comply to FIM regulations and be mechanically fitted to the machine.

4.5 WHEEL RIMS

The modification by drilling to the wheel rims is prohibited other than for spokes, valve, security bolts or tyre retention screws. If the rim is modified for tyre security bolts, or tyre retention screws etc. then they must be fitted.

4.6 ALL CONTROL LEVERS

All ball ended levers (fitted to any machine) must be a minimum of 16mm min diameter. The end of levers when closed must not be situated wider than the furthest extremity of the handlebar.

4.7 FOOTRESTS AND HANDLEBARS

The footrest for the driver must be positioned to give easy access to any control pedal.

The ends of the footrest must be rounded with a spherical radius of not less than 8mm viewing from front and end of footrest.

Footrests must be mounted on an independent pivot.

The ends of the handlebars on all motorcycles shall be rounded or protected.

When light alloy handlebars are used, the distance between the two extremities of the clamping area (or of the two clamps) must not be less than 120mm and handlebar clamps must be very carefully radiused and engineered so as to avoid fracture points in the bar.

Handlebars must be equipped with an appropriate protection pad on cross bars where fitted.

Maximum handlebar width (Solo machines)

85cc/125cc: min 650mm max 850mm

140cc/250cc/350cc/500cc: min 700mm max 900mm

4.8 FRONT ENGINE PLATES SOLO – MACHINES

Where appropriate, the void between the front engine plates of Solo machines below the dirt shield, if fitted, must be covered with a permanently fixed shield or plate.

4.9 OPEN TRANSMISSION GUARDS

The primary transmission must have a fully enclosed guard. The cutting of the guard is only permitted to expose the clutch pressure plate and allow adjustments to the clutch springs.

An additional protection must be provided to prevent a broken primary chain from flying upwards. This can be provided by either a fully enclosed steel chain guard or, if a plastic chain guard is used, a steel bolt of 10mm minimum diameter, placed outside the bottom rear quadrant of the clutch sprocket. This bolt, if damaged, must always be completely replaced.

On all machines chain guards must be fitted to cover the entry to the gear box and rear wheel sprockets.

4.10 IGNITION CUT-OUTS

An ignition cut-out operated by a lanyard which disables the machine in the event that the driver dismounts must be fitted to all machines.

Cut-outs must function when the lanyard is pulled from any direction.

The lanyard must be non-elastic and made of one constant material. Coiled telephone cable or similar materials are not permitted.

The cut-out must operate on the low voltage circuit and be fail safe when operated.

In addition, any part of the cut-out which remains live after actuation must be shrouded in order to prevent accidental contact re-establishing the current flow.

The use of the handlebars or front forks as part of any circuit is not permitted.

The length of the cut-out lanyard must be short as possible and attached to the competitor's/mechanic's wrist whenever the engine is running including push starting the machine and warming up the engine.

Cut-outs will be checked prior to practice. In cases where there are time limitations or noise constraints, cut-outs will be tested as the machine enters the track for first practice.

Machines must not be started before Technical Inspection – cold engines only.

4.11 CARBURETTORS OR OTHER AIR INPUT CONTROL INSTRUMENTS

All Track Racing engines must be fitted with one carburettor with a maximum choke size of 26mm for 140cc and 34mm for 250cc, 350cc and 500cc engines + 0.1mm circular shape.

Air Filters: Air filters can only have a dust prevention fluid added to them, any other additive is prohibited.

4.12 SUPERCHARGERS

The use of superchargers and turbo chargers on Solo machines is prohibited.

4.13 CHASSIS CONSTRUCTION

The use of titanium in the construction of the frame, the front forks, handlebars, swinging arm and swinging arm spindle, front and rear wheel spindles is strictly forbidden.

The use of light alloys for wheel spindles is also forbidden.

The use of titanium alloy nuts and bolts is allowed. The use of a Nylock nut or nut with a split pin is recommended on the front wheel spindle.

4.14 EXHAUST SYSTEMS AND CONTROL OF EXHAUST SOUND LEVELS

Solo – The exhaust system of a Solo machine must not extend beyond the outer circumference of the rear tyre.

Between the silencer and the tyre a maximum gap of 60mm must not be surpassed.

The exhaust fumes must be discharged from the system horizontally and parallel to the centre line of the machine.

The exhaust pipe of a Solo track racing motorcycle must be fixed to the cylinder head and frame with a minimum of three clips (the point of fixture at the cylinder head is considered as one clip).

The diameter of the exhaust pipe must not exceed 50mm diameter or an equivalent area and must remain constant up to the silencer.

The outlet area of the silencer must remain constant over a length of 50mm and must not exceed 45mm or an equivalent area.

500cc Solo and Sidecar Machines – must use a 2015 FIM homologated silencer.

The only exception are machines using engines not designed for Track Racing where an alternative silencer must be used and will be subject to sound control using the new FIM 2 metre Max method of testing.

250cc and 350cc Solo Machines – must use a FIM homologated silencer.

The only exception are machines using engines not designed for Track Racing where an alternative silencer must be used and will be subject to sound control using the FIM 2 Metre Max Sound Levels.

Pre 75 and Upright Solo Machines – must use a FIM Homologated silencer.

The only exceptions are machines using engines not designed for Track Racing where an alternative silencer must be used and will be subject to sound control using the FIM 2 Metre Max Sound Levels.

1000cc Sidecar Machines – will be subject to sound control using a 'Ride By' method with a maximum sound level of 85dBA. The sound meter will be positioned in the middle of the centre green opposite the finish line, the sound meter will face the finish line or directly opposite on the back straight if the wind is blowing towards the sound meter.

If a machine is over the maximum sound level and the competitor disputes the sound meter reading, the machine will be tested to the '2 Metre Max Method'.

If the competitor refuses to undertake the '2 Metre Max' sound test or if the machine cannot be tested to '2 Metre Max' sound method satisfactorily (e.g. the engine will not rev to near the maximum revs) the 'Ride By' sound reading will prevail without appeal.

200cc and Lower Machines (including 140cc) – will be subject to sound control using the current ACU sound control method.

For Sidecar Category B1(c) 500cc exhaust systems see specification 4.16(b).

All Machines – The outside shell of a silencer must form one integral unit in order to prevent any parts being dropped during a race. The end of the pipe must be cut at a right angle.

The silencer must be fixed to the frame with at least one clip. In addition, for reasons of safety, a second flexible coupling must be fitted from the first third of the silencer to the frame (for example: a steel cable of at least 3mm diameter as short as is practical).

The use of intermediate expansion boxes on two-stroke machines is permitted.

All Sidecars (except 1000cc Left Hand class) – Any exhaust pipes exposed across the front of a machine MUST be covered.

4.15 SPECIFICATION OF THREE WHEELERS CATEGORY 1 (1000CC SIDECARS)

All motorcycles in Group B1 (a, and b) shall comply with the following:

- a) The three wheels shall be each of at least 400mm (16") in diameter measured over the outside of the tyre.
- b) Where wheels are not wire spoked, they must be enclosed with a disc.
- c) The wheel track, or lateral distance between tracks, shall be at least 800mm (32").
- d) Chains: The top and bottom runs of the drive chains and points of connection must be shielded.
- e) A passenger must be carried in addition to the rider.
- f) All Sidecars must be on the left hand side of the motorcycle except where special dispensation has been granted for races confined to Sidecars affixed to the right-hand side of the motorcycle.
- g) All Sidecars must be rigidly fixed to the motorcycle. On level ground the maximum incline of the Sidecar wheel must not exceed 25 degrees. The maximum incline of a Class B1 (a) (1000cc) motorcycle must not exceed 5 degrees from the vertical.
- h) The Sidecar wheel must be completely covered on the outside by a disk extending to the wheel rim.
- i) No light alloy bolts shall be used in the attachment of the Sidecar or Sidecar wheel.
- j) The Sidecar wheel may be covered by a fairing. If such a fairing is fitted it must be constructed of fibreglass, plastic or similar material and must not provide a danger to any competitor. No part of any Sidecar fairing may extend beyond a vertical line drawn through the rear edge of the back tyre. If the Sidecar wheel is to be enclosed by a fairing it must be contained within a continuous 25mm horizontal supporting bar, fixed rigidly to the Sidecar platform at Sidecar floor height.
- k) On the right hand side of the machine, any single projection within the diameter of the rear wheel and tyre must not exceed 100mm (4") measured horizontally from the outside of the rear wheel fork slot. Where a single projection as an extension to the rear spindle is used, this must have a minimum diameter of 25mm, be ball-ended and covered with a rubber ferrule.
- l) The maximum capacity of machines permitted in Sidecar races shall be: Class B1 (a and b) maximum 1006cc, unsupercharged, 650cc supercharged maximum.
- m) For all 1000cc Sidecar machines – Class B1 (a and b) – dirt deflectors must be used. Where a machine is fitted with a dirt deflector it will replace the mudflap.
- n) No part of the passenger hand-rail on a Sidecar may be less than 255mm from the outer edge of the Sidecar (this includes the wheel and wheel arch).
- o) The front of the Sidecar chassis must allow reasonable lift of the rear wheel. Where foot boards are fitted to the motorcycle, there must also be reasonable lift of the Sidecar wheel before the foot boards foul the ground.
- p) Protection for the passenger must be provided on three-wheelers from the rear wheel, the primary and final drive chains of the motorcycle and from the Sidecar wheel.
- q) The front and rear wheels, when measured from the centre lines of each wheel at ground level (in direction of forward travel and with correctly inflated tyres) may be displaced by a maximum of 75mm.
- r) Petrol or Methanol, of a commercial make, is the only permitted fuel. The use of octane boosters is forbidden. On liquid cooled engines, an overflow pipe must direct any overflowing coolant away from the rider and passenger into a catch tank.
- s) The use of fuel additives is prohibited, with the exception of oil for two stroke engines. Fuel injection is permitted. Fuel tanks must be constructed of a material that will neither shatter nor splinter upon impact.

4.16 SPECIFICATION OF THREE WHEELER CATEGORY B1(C) 500CC

- a) **General Specification.** For all races, only single cylinder 4-stroke engines are allowed. The maximum capacity is 500cc, 4 valves maximum fitted with one carburettor, maximum diameter 38mm and one spark plug.
- b) **Exhaust System.** The exhaust must not extend beyond the outer circumference of the rear tyre and must not end further forward than the centre of the rear wheel. Between the silencer and the tyre there must be a maximum gap of 60mm. On a Sidecar machine the exhaust must discharge horizontally and towards the rear, at a maximum angle of 30 degrees to the axis of the machine, and at the end be of a constant diameter over a distance of 50mm. FIM homologated silencers must be used, in line with the current sound control regulations and a FIM approved heat shield must be fitted.
- c) **Brakes.** Brakes are not permitted on 500cc Sidecar motorcycles.
- d) **Footrests.** For Track Racing Sidecars the footrest on the opposite side to the Sidecar must be protected at the front by a crash bar connected to the frame so that injury or breakdown to other participants is prevented. The footrest must be fitted at a height of at least 150mm from the ground.
- e) **Mudguards and Wheel Protection.** For 500cc Sidecars, the mudguard of the rear wheel and the mudguard of the Sidecar must extend within 200mm from the ground. Protection from the Sidecar wheel and the rear wheel for the passenger must be provided down to the level of the Sidecar platform. The Sidecar wheel must either be completely covered by a disc extending to the wheel rim, or the Sidecar mudguard must extend downwards on the outside of the centre of the wheel spindle.
- f) **Tyres.** No specification for front and Sidecar tyres. For the rear tyre the overall width must not exceed 100mm and the only tyres allowed are those with Track Racing, Speedway or Trials tyre tread pattern.

- g) **Wheels and Rims.** Front wheel: minimum rim diameter 18", minimum diameter of wheel spindle 15mm, solid steel shaft permitted only, minimum diameter of spokes 3.5mm M4 steel, spoke facing must cross twice. Rear wheel: minimum rim diameter 18", maximum rim diameter 22", minimum diameter wheel spindle 17mm, solid steel shaft permitted only, minimum diameter of spokes 4mm M4 steel, spoke facing must cross twice. Sidecar wheel: maximum rim diameter: 16". Maximum wheel inclination of 30°, measured from the vertical to the inside (controlled by angle measuring instrument and spirit level).
Position: One-sided wheel spindle diameter of 25mm minimum at the point of the highest moment of deflection; solid steel; or, diameter of 15mm if supported on both sides of the wheel. The Sidecar wheel spindle must not be welded in position. It must be screwed on, for example, by collar or clamp, with at least three M8 screws. The minimum length of the clamp is 100mm. For construction using a clamp, protective devices against the loss of the component or failure of the clamp must be provided. Clamp construction in two places is forbidden. All wheel shafts must be secured by a nut with a secondary safety device e.g. split pin, R clip or circlip.
- h) **Sidecar Specification.** The minimum ground clearance at the front edge of the Sidecar platform is 150mm. The ground clearance of a laden Sidecar (with a rider and passenger) must be no less than 100mm at any point. The distance between the tracks left by the centre lines of the rear motorcycle wheel and the Sidecar wheel must be at least 800mm and not more than 1100mm. On the opposite side of a 500cc Sidecar, the exhaust pipe must not extend more than 330mm from the centre of the machine. On the Sidecar side, the exhaust pipe must not extend beyond the width of the Sidecar. The furthest extremity of the exhaust pipe must not exceed the vertical line drawn at a tangent to the rear edge of the rear motorcycle tyre or the rear edge of the Sidecar platform whichever is shorter. The outside of the 500cc Sidecar wheel shall be provided with horizontal tubular protection (minimum tube diameter 25mm) fixed at the same height as the Sidecar wheel spindle. No component shall protrude beyond this protection. The inclination angle of the motorcycle must not exceed 15°.

4.17 ADDITIONAL (OLD AND NEW) SIDECAR CLASSES

1) Pre 1980 Class

- For machines fitted with British made twin cylinder engines, initially designed for mass produced road bikes (up to 650cc supercharged and 1000cc naturally aspirated).
- For 650cc machines actual maximum capacity will be based on manufacturer's standard rebore sizes
- Chassis and running gear to be based upon the type commonly in use pre 1980.
- British twin shock, no 2 speed gear boxes.
- Dirt deflectors are not mandatory in this class. If a dirt deflector is not used, a flexible mud flap must be securely fixed, minimum thickness 10mm and 150% of the overall tyre width. The bottom edge of the mud flap must be within 35mm of the ground when laden.
- All current safety and environment requirements must be respected.

2) 500cc Twin Cylinder Class

- For machines fitted with parallel twin cylinder engines initially designed for mass produced road bikes (naturally aspirated)
- Standard 500cc air cooled parallel twin, mass produced, running on standard petrol. Carburettors and electrics must be standard manufacture for the engine used in the motorcycle.
- Chassis to be based on current requirements.
- Dirt deflectors are not mandatory in this class. If a dirt deflector is not used, a flexible mud flap must be securely fixed, minimum thickness 10mm and 150% of the overall tyre width. The bottom edge of the mud flap must be within 35mm of the ground when laden.
- All current safety and environment requirements must be respected.

4.18 TRACTION CONTROL

The forward motion of a motorcycle must be controlled by the rider only, and the regulation of speed shall be through the use of throttle, clutch, gears and brakes when fitted.

Throttle opening must be controlled by cable only, no 'fly bye wire' type throttle actuation is permitted. Rider aids whether a part or full system fitted on a machine/engine CANNOT be used and are not permitted.

4.19 FUEL

Fuel may be methanol or unleaded petrol. Please refer to the ACU and FIM fuel regulations for physical properties, fuel test costs, and penalties for non-compliance.

Power boosters and octane boosters are forbidden.

Fuel may only be retailed from a point of a minimum of 7 metres from any other vehicle.

The area must be roped off and the retailers must display 'No Smoking/Vaping' and 'No Naked Lights' signs, in addition to any other requirements requested by the local authorities.

Fuel must only be dispensed in clearly labelled containers.
 No smoking also applies to all electronic cigarettes.
 Mobile phones should not be used when refueling machines.

4.20 OIL CATCH TANKS

Must be securely fitted to all four stroke machines using a total loss lubrication system.
 Oil catch tanks must be connected at all times and be emptied after each race.
 Oil catch tanks must be securely fitted to all machines with engines that require an oil breather system.

4.21 NUMBER PLATES

Whenever number plates are required to be used at an event, they will be three in number and must comply with the following requirements. Both classic and Pre-75 machines may be granted a dispensation to this rule.

Number plates must be of durable construction with the minimum dimensions height 235mm × width 285mm.

The front plate must be rectangular with 50mm radius to the corners.

The plates must be flat or slightly curved (not more than 50mm from the true plane) and must not be otherwise bent or obscured in any way.

One plate must be carried forward and not more than 30 degrees from the vertical and the others must be facing outwards and vertical (one on each side of the machine).

Side facing plates can be oval.

They must be so fixed that they are clearly visible and not obscured by any part of the machine or by the rider or passenger when in the riding position.

It is the responsibility of the competitor to ensure that racing numbers are clearly visible for lap scorers.

The minimum dimensions of the figures must be: height 140mm, width 80mm, width of stroke 25mm and the space between any two figures 15mm.

The number plate size relates to a two digit number.

Should a three digit number be used then an increase in the size of the plate will be required.

Numbers cannot be 'joined up' – single figures only with no outline around the outside of each figure.

The figures must be legible and both figures and background must be in a 'matt' (non-shiny) colour.

The colours shall be as follows:

Front and Side Number Plates Background Colour Number Colour Capacity

Solo's – capacity	Number plate background colour	Number colour
250cc	Green	White
Over 251cc to 350cc	Blue	White
351cc to 500cc	Yellow	Black

Sidecars – capacity	Number plate background colour	Number colour
B1c	Yellow	Black
B1a, B1b	Black	White
GT140	Black	White

Where yellow, green or blue are required the colours shall comply with BS4800: 1972 as follows:

Yellow 10E526, Green 14E53, Blue 18E53.

Any other number plate or any marking on the motorcycle that might be confused with a number plate must be removed before the rider is allowed to start.

Streamlining – Streamlining is NOT permitted on any Solo machine. Streamlining is defined as any addition to the handlebars or to the frame of the machine, the effect of which is to shield the rider's arms, legs or body from the air stream.

4.22 QUADS

Grass Track Quads are limited to a maximum engine capacity; a two stroke engined quad should not exceed 550cc. Whether two stroke or four stroke the engine must have no more than two cylinders up to 550cc.

The maximum engine capacity for a four stroke engined quad should not exceed 700cc and be single cylinder.

Quads eligible for the 250cc class are allowed a 10% oversize but are not allowed to exceed 275cc.

Motocross riding gear must be worn at all times.

Track safety roping is to be set out as in accordance with the Grass Track Sidecar safety roping regulations.

Lanyard cutouts must be used and attached to the rider's wrist as per Track Racing Regulations.

Youth – Quads are not permitted in youth events without agreement from the Track Racing Committee.

For Quads a third number plate must be fitted running parallel with the machine at the rear, readable when facing the side view of the machine. The mounting bracket must not exceed 25mm in a vertical plane from the mounting point.

All other specifications as in Quad/ATV Motocross Standing Regulations and National Sporting Code Appendix D.

4.23 CLASSIC PRE-75 SOLO GRASTRACK MACHINES

These guidelines are for Solo machines in accordance with equipment which was in common use up to 1975.

- a) **Standing Regulations.** All machines must comply with the Standing Regulations for Track Racing as given in the current edition of the ACU Handbook with the exception of the following:
- b) **Frame.** The frame should ensure that the engine is mounted in a near upright or vertical position. The rear suspension, if fitted, should incorporate a swinging arm with suspension units mounted on each leg of the swinging arm and onto the rear sub frame. Monoshock rear suspension is not permitted. Leading link style forks are not permitted – only telescopic style front forks are permitted
- c) **Four Stroke Engines.** The engine will have one inlet and one exhaust valve per cylinder. The inlet port of the cylinder head must be angled towards the right hand or left hand side of the machine. Central carburettor cylinder head design are not permitted. On a pre unit construction type engine, the lubrication system will be total loss type with an oil catch tank fitted as per Grass Track Technical Rule 4.20. On a unit construction type engine a recirculatory oil system will be permitted.
- d) **Two Stroke Engines.** The engine will be of air cooled design and be of a type commercially available up to 1975. Water cooled engines not permitted.
- e) **Carburettor and Ignition System.** No restriction.
- f) **Transmission System (gearbox and clutch).** No restriction.
- g) **Mudguards, Number Plates, Dirt Shields etc.** In keeping with the styles and types available of the period (plain designs and colours are preferred)
- h) **Wheel Sizes.** No restriction.
- i) **Brakes.** As per Grass Track Standing Regulations rule 4.2.

The object of the above guidelines are to ensure that all Club Officials and competitors are aware of the construction requirements so that the possibility of a dispute at an event is reduced. It is recognised that certain parts will be of modern manufacture, this will be accepted so long as the above guidelines are adhered to.

4.24 Post 1976 UPRIGHT SOLO GRASSTRACK MACHINES

These guidelines are for Solo machines in accordance with equipment that was in common use between 1976 and 1990.

- a) **Standing Regulations.** All machines must comply with the Standing Regulations for Track Racing as given in the current edition of the ACU Handbook with the exception of the following:
- b) **Frame.** The frame should ensure that the engine is mounted in a near upright or vertical position. The rear suspension, if fitted, should incorporate a swinging arm with suspension units mounted on each leg of the swinging arm and onto the rear sub frame. (MONOSHOCK REAR SUSPENSION IS NOT PERMITTED) Both telescopic style and leading link type front forks are permitted.
- c) **Four Stroke Engines.** The engine will be of a type commercially available post 1976. The engine will have two inlet and two exhaust valves per cylinder. The inlet port of the cylinder head may be angled towards the right hand or left hand side of the machine or mounted centrally from the cylinder head. The engine the lubrication system may be either a recirculatory system or a total loss system. If the engine is a total loss system, then an oil catch tank must be fitted as per Grass Track Technical Rule 4.20.
- d) **Four Stroke Engine Carburettor.** Must have a maximum choke/venturi diameter of 34mm.
- e) **Two Stroke Engine.** The engine will be of a type commercially available between 1976 and 1985. Both aircooled and water cooled engines are allowed.
- f) **Two Stroke Engine Carburettor.** Must have a maximum choke/venture diameter of 38mm.
- g) **Ignition system.** No restriction.
- h) **Transmission system (gearbox and clutch).** No restriction.
- i) **Mudguard.** Mudguards, number plates and dirt shields etc. will be in keeping with the styles and types available of the period.

- j) **Wheel sizes.** No restriction.
- k) **Brakes.** As per Track Racing Technical rule 4.2 (ACU Handbook).
- l) **Silencers.** All machines must adhere to the current ACU Sound Regulations, as set out at 4.14 above.

The object of the above guidelines are to ensure that all Club Officials and competitors are aware of the construction requirements so that the possibility of a dispute at an event is reduced. It is recognised that certain parts will be of modern manufacture; this will be accepted so long as the above guidelines are adhered to.

4.25 FORMULA GRASS TRACK

All machines must comply with the Standing Regulations for Track Racing as stipulated in the current edition of the ACU Handbook except for the following:

- a) Honda Engine – a standard street legal 100cc – 125cc single cylinder, two valve, 4 stroke air cooled. Standard specification as per HAYNES MANUAL i.e. Bore 56mm Stroke 49.5mm comp ratio 9.5:1 etc
- b) No engines designed for 'Off Road' use e.g. XR range
- c) No interchanging of parts that would alter the standard specification of the engine.
- d) Standard up to 125cc single cylinder, two valve, 4 stroke, air cooled horizontal engines (e.g. Pit bike style engine).
- e) Gear Box – standard ratios only. No close ratio gears. No pinions to be left out of the gear box, the full cluster must be fitted.
- f) Carburettor – any make of carburettor. Carburettor must be upright.
- g) Ignition – any type including electronic. Rotor and stator plate may be removed.
- h) Fuel – petrol, normal pump grade. METHANOL IS NOT ALLOWED
- i) Tyres
 - Senior Class – Rear tyre restricted to Grass Track/Speedway/Trials tread patterns only.
 - Maximum width 3.75 ins (95mm) No tyre cutting in any form will be allowed.
 - Youth Classes – no restriction as per ACU technical regulation 4.3
- j) Classes and number plate colours

Class	Background Colour	Number Colour
Cadets/Auto Cadets 6–8years	White	Black
Cubs 9–12 years	Red	White
Juniors 12–16 years	Green	White
Seniors 16+	Black	White

4.26 GT140 RULES

- a) Standing regulations must comply for Track Racing machines with current technical regulations for the GT 140 class.
- b) Frame can be a Grass Track twin shock or mono-shock incorporating a swinging arm with suspension, Speedway rear subframe IS NOT permitted.
- c) Forks can be any type e.g., leading link or telescopic.
- d) Wheels: Front – 21/23 inch, Rear – 22 inch as per current regulations
- e) Engine: 140cc with a bore of 56 and stroke of 57 with a maximum of 2 valves, these must be 140cc factory manufactured engines only (no KLX type engines to be used)
- f) TB heads allowed - Takagawa or any other none standard head **NOT** allowed.
- g) Titanium engine internal parts **NOT** allowed.
- h) Ignitions: Should be of a generator type as manufactured.
- i) Fuel: Petrol only, methanol IS NOT permitted.
- j) Carburettor inlet must not exceed a maximum diameter of 26mm for a minimum of 2mm either side of the slide. Carburettor must be upright.
- k) Number plates (refer to 4.21) must be displayed on the front and either side at the rear of the machine.
- l) Brakes ARE NOT permitted as per Grass Track regulations 4.2.
- m) The rear silencer must be fitted with a retaining wire to ensure it does not become detached from the motorcycle during racing.
- n) Mudguards: Regular Grass Track mudguards or huggers kits are permitted.
- o) 'Ignition Cut Out' system must be fitted to disable the engine via a lanyard attached to the rider.
- p) Chain: The rear chain must be covered on any area where the chain meets the front and rear sprocket.

4.27 INTERNATIONAL 125CC FOUR STROKE SPECIFICATION

For International 125cc and 250cc four stroke specifications, refer to current FIM/FIM EUROPE technical specifications. These classes run without brakes.

Other than events run to FIM/FIM EUROPE rules, brakes must be fitted.

Braked and non braked machines MUST NOT compete in the same race.

The specification of machines in these classes will be in accordance with FIM Rules which are available from ACU Head Office.

5 SAND/BEACH RACING

As per Grass Track Standing Regulations with the exception of:

- a) Maximum twelve riders where there is an 'on-track' start
- b) MX classes – Specification of the motorcycle: Refer to section 5 of the MX Standing Regulations for basic specification of motorcycles, which MUST ALSO INCLUDE:
 - Lanyard cut outs
 - Chain guards as per Grass Track standing regulations.
 - MX classes to also include Enduro machines. ALL other Grass Track Standing Regulations apply to MX classes

5.1 THREE WHEELER CATEGORY 1. GROUP B1 (A, B)

- a) Maximum Capacity of Sidecars 1040cc (to accommodate FIM Sidecar Speedway regulation machines).
- b) Supercharged up to 650cc. 651cc to 1040cc – not supercharged.

6 FLAT TRACK

6.1 DIRECTION OF RACING.

Flat Track Racing will take place on an oval circuit or TT circuit (i.e. TT circuit with mainly left hand bends but can have up to two right hand bends and jump) and will run in an anti-clockwise direction.

6.2 NUMBER OF RIDERS.

Track less than 400 metre in length – A maximum of twelve riders on the track in any race or practice session.
1/2 mile, Mile or TT Track – a maximum of sixteen riders on the track in any race or practice session.

6.3 PRACTICE.

The practice session at the beginning of the meeting is compulsory for all riders.

Race Distances. The duration of races will be as follows:

- six to eight laps for heat races,
- eight to ten laps for lastchance/Semi Finals,
- twelve to sixteen laps for the Grand Final.

6.4 TIME PENALTY.

Any rider not at the start line within two minutes of being called will be excluded from the race.

6.5 STARTING INFRINGEMENT.

If a rider touches the tapes or jumps the start, the Referee will place them twenty five metres back from the start line.

6.6 FLAGS AND SIGNALS.

Riders must obey all signals given to them on the track.

Chequered Flag – The finish of a race or practice sessions.

Yellow Flag – Danger in this section of the track, overtaking is prohibited.

Red Flag or Red Light – The practice or race is being interrupted. Riders must slow down, return to the pits and await further instructions from the Clerk of the Course.

7 FLAT TRACK TECHNICAL REGULATIONS

The basis for the specification will be Motocross, Enduro, Supermoto and Dirt Track machines.

- a) Engine Displacement. 2 stroke 125cc to 500cc, 4 stroke 250cc – unlimited.
- b) Besides the compulsory adjustments, alterations may be applied to the frame and the appearance of the

- machine.
- c) The front forks must not protrude more than 5cm above the upper attachment of the suspension.
 - d) The rear wheel must be able to stop instantly, so an efficient braking system on the rear wheel is mandatory.
 - e) Front wheel brakes are prohibited and all the components relating to a front brake must be removed.
 - f) Only the following tyres are permitted: Maxxis DTR, Dunlop DT, GoldenTyre FT, Barum DT.
 - g) The rear sprocket should be guarded with a shark fin type protector.
 - h) The gearbox sprocket must be suitably protected.
 - i) Only fuel that can be purchased from a roadside petrol station is permitted.
 - j) A lanyard type cut-out must be fitted to all machines.
 - k) Foot pegs should be in their original position on the frame or no lower than the frame itself.
 - l) The noise level of any machine must not exceed 89dBA at 2 metres.

8 1000CC SIDECAR SPEEDWAY REGULATIONS

8.1 DEFINITION

To be deemed as eligible for competition in 1000cc Sidecar events on Speedway circuits, the motorcycle shall be in conformity with the following requirements:

The motorcycle must have three rolling wheels.

The Sidecar wheel must be on the left hand side of the motorcycle.

The drive must be transmitted to the track surface through the rear wheel of the motorcycle.

The motorcycle must at all time carry a rider and a passenger.

Brakes are not permitted.

Rear wheel suspension is optional.

The passenger must sit astride the motorcycle

The motorcycle shall always race in a clockwise direction.

8.2 DIMENSIONS

The overall length from the leading edge of the front tyre to outside of the rear mudguard must not exceed 2600mm.

The overall width must not exceed 1500mm.

The wheelbase, measured from the centre of the front spindle to the centre of the rear spindle, must measure between 1280mm and 1800mm.

The wheel track, measured between the centre lines of the track left by the rear and Sidecar wheels, shall be a minimum of 800mm and a maximum of 1100mm.

The front and rear wheel must be aligned as such that the centre line of the tracks made by the motorcycle is proceeding directly forward, must be no further apart than 75mm.

The width of the running board on the right of the motorcycle must not exceed 400mm.

The angle of inclination of the main body of the motorcycle must not exceed 10° from the vertical.

The minimum ground clearance at any point of the Sidecar shall be 75mm unloaded.

8.3 ENGINE

The engine capacity shall not exceed 1000cc. Engines may be bored up to 1006cc (no further tolerance).

8.4 MINIMUM WEIGHT:

180kg with empty fuel tank. Coolant tank must be full.

8.5 FUEL, OIL AND COOLANTS

Petrol or methanol, of a commercial make, is the only permitted fuel. The use of octane boosters is forbidden. On liquid engines, an overflow pipe must direct any overflow coolant away from the rider and passenger into a catch tank.

The use of fuel additives is prohibited, with the exception of oil for two stroke engines. Fuel injection is permitted. Fuel tanks must be constructed of a material that will neither shatter nor splinter upon impact.

8.6 EXHAUST SYSTEMS

Exhaust pipes and silencers may be of a "baffle" or "absorption" type and must fulfil the requirements concerning noise control.

An exhaust extraction (megaphone types) effect must not be caused by the positioning of any tapered, conical or

other shaped parts.

The exhaust pipe must be fixed to the cylinder head and frame with a minimum of three clips (the point of fixture at the cylinder head is considered as one clip). The silencer must be fixed to the frame with at least one clip.

Additionally, a second flexible coupling must be fitted from the first third of the silencer to the frame (steel cable of at least 3mm diameter for reasons of safety) or a solid steel spring.

Exhaust fumes must be discharged towards the rear but not in a manner as to raise dust, foul the tyres, or inconvenience a passenger, or any other riders.

The entire exhaust system must be contained within the fairing, to ensure that the exhaust system cannot come in contact with any rider, passenger, or other motorcycle.

8.7 WHEELS, RIMS AND TYRES

The front tyre and Sidecar tyre must be of a 'trial' type pattern. Maximum sizes for rear wheel rim: 5.00" x 19".

The Sidecar wheel diameter must be between 16 and 19 inches and must camber inwards.

Cast or welded wheels must be covered with a disc or other suitable shield.

On level ground the maximum incline of the Sidecar wheel must not exceed 25 degrees, with the Sidecar being fixed rigidly to the motorcycle

The Sidecar wheel can be mounted with plates on both sides. If this situation exists the spindle diameter must be min. 12mm.

If the Sidecar wheel is mounted with a bracket on one side, the spindle diameter must be min. 20mm.

The rear and front wheel must be fitted with knockout spindles.

The use of light alloys and titanium in the manufacturing of wheel spindles is forbidden.

8.8 SIDECAR PLATFORMS

If the Sidecar platform is not an integral part of the frame, the platform must be rigidly fixed to the motorcycle in at least four places.

Any space between the Sidecar platform and the rear wheel of the motorcycle must be covered to ensure that the passenger's hands and feet cannot be trapped in the driving chain or the rear wheel.

The Sidecar wheel must be contained within a continuous 25mm horizontal crash bar, fixed rigidly to the Sidecar platform at Sidecar floor height.

Any open area in the Sidecar platform inside the continuous crash bar, and on the running board on the near-side, must be filled with a suitable material to prevent either the rider or passenger from trapping their feet.

8.9 DIRT DEFLECTORS, MUDGUARDS, FAIRINGS

A dirt deflector is compulsory and must be of a type homologated by the FIM. The dirt deflector flap holder must be constructed of a non-metallic material.

The dirt deflector must be fitted adjacent to the rear wheel and is required to deflect "wheel-spray" or track surface material downwards in order to minimise the inconvenience caused to other riders, spectators, and the soiling of track-side notices and equipment.

The return mechanism must have a minimum pre-load of 6 kilos (to be monitored during the season and reviewed if required). The lower flap edge of the deflector must be 35mm (± 5 mm) from the track surface.

The dirt deflector arm must be modified to ensure that the blade and flap are correctly positioned behind the rear tyre.

A rear mudguard must be fitted and extend from the rear seat to a maximum of 150mm from the ground (when the Sidecar is laden).

The outside of the Sidecar wheel and tyre must be covered by a non-rotating shield or fairing. This fairing must be securely fixed to the Sidecar and outside of the crash bar.

All fairings and nose cones must be constructed of fibreglass, plastic, or similar material. They must be smooth, free of any sharp or protruding edges, and must not provide a danger to any other competitor.

The minimum clearance between streamlining and the ends of the handlebars or their attachments is 30mm with the front wheel in any position. No aero foils or similar devices are permitted.

No part of any nose cone or fairing may extend beyond a vertical line drawn through the leading edge of the front tyre.

No part of the Sidecar fairing may extend beyond a vertical line drawn at a tangent to the rear edge of the backtyre.

8.10 FRAME

The use of titanium and composite materials in the construction of a frame is completely forbidden. An efficient steering damper may be installed.

8.11 THROTTLE CONTROLS AND IGNITION CUT OUTS

Throttle controls must be self-closing when not held by the hand.

The throttle must be controlled by cable only; no 'fly by wire' type throttle actuation is permitted.

Rider aids, whether part or full system fitted on a motorcycle/engine CANNOT be used and are not permitted.

An ignition cut-out must be fitted on the handlebar, as close as practical to the throttle. The switch must cut off the circuit of the electrical supply by the simple action of pulling a lanyard or a non-elastic cord (with a maximum length on 30cm), attached to the rider's right wrist.

Note: Interrupting the electric supply by grounding the circuit is not a sufficient measure.

The ignition cut-out lanyard must be attached to the operator's wrist when the engine is running.

Ignition cut outs will be checked prior to practice to ensure they function correctly.

8.12 MEETING FORMAT AND REGULATIONS

Details of the meeting formats and associated meeting regulations will be confirmed in the form of Supplementary Regulations that will be issued by the ACU TRC prior to the start of each season's series.

9 YOUTH COMPETITOR REGULATIONS

The following regulations apply to youth competitors only.

9.1 ORGANISING PERMITS

An application for a permit to organise a competition shall be made on the appropriate form and sent to the appropriate Permit Issuing Officer as per the National Sporting Code. Permits for events where revenue is to be obtained from the general public will only be issued if the proceeds are donated to charity, a Steward must also attend any such meeting. If revenue is to be obtained from the general public, it must be clearly stated when applying for a permit. Additional insurance must also be taken out and only events of National status and above will normally be granted permission.

9.2 JOINT YOUTH/ADULT EVENTS

Youth classes may be included in adult events of below National status. The practice and racing for Youth classes must be run separately from the Adult classes and the age groups also separated. Adult clubs promoting joint events shall organise these under a joint permit, issued by the local Centre.

9.3 ADVERTISING

Commercial advertising in connection with Youth competitors in the press or in any publication is not permitted.

Approval must be obtained from the ACU Headquarters, before any club/rider appears on TV or any other media.

9.4 RESPONSIBILITY FOR YOUTH ENTRANTS

The parent or guardian must accompany a Youth entrant to a meeting and stay for the duration that the rider is present. A competitor deemed unfit by First Aid personnel will be withdrawn from the meeting.

9.5 AGE GROUPS, ENGINE CAPACITY AND NUMBER PLATES

When a competitor reaches the maximum age for his or her group, they may continue in that group until the end of the calendar year, or upgrade on his or her birthday.

No competitor may compete before his/her 6th birthday. Competitors may compete until the end of the year in which their 17th birthday falls.

A competitor may be upgraded to compete in Adult competitions on or after his/her 15th birthday, up to a maximum capacity of 250cc and may only revert to Intermediate Class Youth competition. There are no restrictions to the type or level of youth event that a competitor may enter.

All competitors must be capable of sitting on their machines at the start line (unaided) with the machine in an upright in-line position with one foot firmly on the ground and the other on the footrest.

Production Motocross machines will not be allowed in any other Grass Track class apart from the Cadets which must not exceed the stated capacity.

At joint Adult/Youth events, a rider must specify which class he/she will enter and cannot ride Youth and Adult at the same event. The maximum engine capacity sizes as stated in the table below applies to Youth Grass Track The Youth Auto/Cadet Class: The Auto machines and the geared machines in this class can run separately or be amalgamated depending upon the number of entries received by an organiser.

For the British Championship these will be run as separate classes.

For Quads refer to Motocross 2.2 on page 109.

For FIM Gold Trophy meetings and FIM EUROPE European Cups the minimum for each meeting starts on the competitor's minimum age birthday.

The maximum age finishes at the end of the year in which the competitor reaches the maximum age.

Youth competitors are limited to 250cc engine size.

Class	Capacity – Engine Type	Age on 1st January	Number Plate Background Colour	Number Colour
E4	Electric max 1.5kw output Wheel size 12" front and rear (Max)	4-7 years	Green	Yellow
Auto/Cadet	50cc Fixed Auto. 65cc–2 stroke 110cc–4 stroke	6–8 years	White (Auto) Black (Cadet)	Black (Auto) White (Cadet)
Junior	up to 100cc–2 stroke 150cc–4 stroke	9–12 years	Red	White
Intermediate	up to 150cc–2 stroke 250cc–4 stroke	13–16 years	Green	White

MX Classes

Junior 65cc MX	65cc–2 stroke 110cc–4 stroke	7–10 years	Black	White
Inter 85cc MX	85cc–2 stroke 150cc–4 stroke Wheel size 14" rear 17" front	9–12 years	Red	White
Senior 85cc MX	85cc–2 stroke 150cc–4 stroke Wheel size 16" rear 19" front	11–15 years	Green	White

International and European Classes

FIME 125cc European Cup	125cc–4 stroke	10–16 years	Green	White
FIM 125cc Gold Trophy	125cc–4 stroke	12–16 years	Green	White
FIM 250cc Gold Trophy	250cc–4 stroke	14–16 years	Blue	White

Note: The minimum age for each and every category of meetings starts on the competitor's minimum age birthday. The maximum age (where applicable) finishes at the end of the year in which the competitor reaches the maximum age.

Where yellow, green or blue are required the colours shall comply with BS4800: 1972 as follows: Yellow 10E526 Green 14E53 Blue 18E53.

Any other number plate or any marking on the motorcycle that might be confused with a number plate must be

removed before the rider is allowed to start.

9.6 UPGRADING

On reaching the minimum age for the next group, the competitor may upgrade.

Please note that any competitor who chooses to upgrade cannot then move back to the lower age group once they have competed at a higher level.

A competitor may be upgraded into the next higher group before reaching the age normally required subject to the following:

- a) The written agreement of the parent or guardian plus an endorsement by a current Youth Organiser plus the written approval of the Track Racing Committee.
- b) For upgrading from Intermediate class to Dual Youth/Adult 250cc competition: this is only available to competitors from their 15th birthday until the end of the year in which their 16th birthday falls.
The written agreement of the parent or guardian plus an endorsement by a current Youth Organiser plus an endorsement by a National Grass Track Coach plus the written approval of the Track Racing Committee.

In limited circumstances, the Track Racing Committee may give approval to a competitor remaining in a lower class for an additional year following written application. Where approval is given, the competitor will not qualify for any National Championship points for that year.

9.7 AWARDS

Cash awards are not permitted in Youth events.

9.8 HOLDER OF A SPEEDWAY CONTRACT

Riders in possession of a Premiership League contract to a BSPA promoter will not be permitted to compete in Youth Grass Track events.

9.9 CONDUCT

Competitors, parents, guardians or associates failing to obey instructions given by Officials of a meeting or deemed to have unjustifiably or maliciously jeopardised the efficient running of the meeting, will be dealt with in accordance with the National Sporting Code.

9.10 MINORITY CLASSES

If a group has an entry of four or less, the Clerk of the Course, with agreement of the Secretary of the Meeting and parents, will decide if those riders will ride with the group above or below the group the competitors normally ride in. This should normally be the minority group either side, but only at below National status level.

9.11 STARTER'S ORDERS

Only those competitors in the starting area or on a grid will be deemed to be under Starter's Orders. No other competitor is subsequently permitted to start in a race.

No parents or mechanics will be allowed on the start area once competitors have come under Starter's Orders. The only exception being the Auto Cadet and Cadet classes.

A parent or mechanic of a rider in this group will be permitted on the start provided they stand at least six feet/1.8 metres from the rear of the machines at the starting gate.

9.12 CLOTHING

As per Grass Track Standing Regulation 3.2.

10 GRASS TRACK EVENTS HELD ON SPEEDWAY CIRCUITS

10.1 TO BE IMPLEMENTED WHERE ACU/ACU EVENTS/ACU CLUBS HOLD EVENTS ON SPEEDWAY TRACKS.

The ACU Grass Track Regulations shall apply to all Speedway events, where appropriate and the following Supplementary Regulations will become applicable when events of this nature are held.

- a) Permits may only be issued in respect of Speedway tracks that are licensed by the Speedway Control Bureau and maintained to the minimum standard for Speedway racing.
- b) For an ACU club event, the Centre within which the circuit is based will normally issue permits for these events.
- c) A Steward and/or Referee will be appointed by the Permit Issuing authority who will conduct a track inspection prior to the event.
- d) The maximum number of competitors in each race shall be four.
- e) Machines and capacities shall be as in current ACU Grass Track Standing Regulations.
- f) Youth riders must only compete against others in their age groups as in Grass Track Standing Regulations.
- g) Marshals must be appointed to the inside of the track as per Grass Track safety requirements. If a Clerk of the Course/Steward is in control on the track then red warning lights may only be used as a supplement to the Marshals' warning flags. However if a judicial Clerk of the Course/ or Referee is using a control panel then they will operate the red lights when required with Flag Marshals responding immediately in support.
- h) No marshals shall be on the centre green for Sidecar Speedway events.
- i) Two WARNING NOTICES (Type A) must be prominently displayed on either side of the track entrance.
- j) PROHIBITED NOTICES must be displayed in areas to inform spectators of safe areas.
- k) Strictly only appointed meeting Officials shall be allowed on the track or in the centre of the arena during practice or racing.
- l) Strictly only competitors, mechanics and meeting officials shall be allowed in the Pit area during practice or racing. No riding will be allowed in the pits.
- m) Any competitor deemed to be the primary cause of a race being stopped will be excluded from the race.
- n) When a competitor's motorcycle or any part of their body or equipment touches or breaks the starting tapes or prevents the raising of the start gate, then they will be excluded by the Clerk of Course/Referee.
- o) Ambulance and First Aid cover must be in line with ACU Grass Track Standing Regulations.
- p) Track marking and starting gates will be made with white chalk or similar material in contrast to the colour of the track surface and maintained in suitable condition throughout the meeting.

11 TRACK RACING OFFICIALS

11.1 QUALIFICATIONS AND CONDITIONS

Track Racing Officials are divided into two categories: those who are Licensed and those who are Registered. No fees are payable in respect of any licence or registration for the appropriate form of identification issued.

LICENCES: Senior Track Racing Officials are required to hold an ACU licence of the appropriate grade for the performance of their duties.

REGISTRATION: A register is maintained by the ACU of all licensed officials.

11.2 TRACK RACING OFFICIALS WHO REQUIRE A LICENCE

See note below regarding whether a licence and attendance at an ACU seminar is required

Official	Licence Required	Attendance at Seminar/ Training Session
Clerk of the Course/Referee/ Assistant Clerk of the Course	YES (once in any given three year period)	YES (every third year minimum)
Chief Steward	YES (once in any given three year period)	YES (every third year minimum)
Chief Technical Officer	YES (once in any given three year period)	YES (every third year minimum)
Sound Inspector	YES	YES (required for first issue only)

Measurer	YES	YES (required for first issue only)
----------	-----	--

Clubs and Centre's shall only nominate candidates whose aptitude and integrity for the position they can fully justify. Official ACU approval and the issue of a licence is only after the candidates have proved to be competent according to the special requirements for each discipline.

The respective Committees and Panels organise seminars that are compulsory for certain officials. A licence is valid for 3 years unless as otherwise specified.

Note 1: Clerk of the Course Grades//Referee Grades/Levels – Track Racing

Restricted/Centre – must undergo training at a seminar organised by a National Clerk of the Course.

National – must attend a seminar organised and presented by the ACU Track Racing Committee.

International – must attend a seminar organised and delivered by the FIM.

Note 2: Chief Steward Grades/Levels

Restricted/Centre – will be appointed by the Centre as the Permit Issuing Authority.

International/National – will be appointed by the Track Racing Committee as the Permit Issuing Authority.

Note 3: Chief Technical Official – will be licensed by the Technical Panel. The Chief Technical Official will be responsible for the Technical control at an event.

The Technical Panel may restrict the disciplines of licence holders.

Note 4: Measurer – the Measurer is required for ACU National Championships and National status events. The licence is issued by the Technical Panel and may be restricted by discipline.

Licence Fees for Officials: All ACU Officials licences will be issued, free of charge by the ACU.

11.3 TRACK RACING OFFICIALS WHO DO NOT REQUIRE A LICENCE

See note below regarding requirement for training

Incident Officer: may attend Clerk of the Course seminars held at ACU HQ to assist in his/her understanding of the safety requirements needed for organising and staging a successful event.

Secretary of the Meeting: will receive training at events via mentoring from personnel within the club or via support from another club's Secretary of the Meeting.

Note: an ACU Secretary of the Meeting Guidance booklet is available for reference purposes – please contact the ACU Track Racing Secretary for further information.

Technical Official: will receive training via the Chief Technical Officer at race meetings. May also attend Regional training seminars.

Club Stewards: may attend Regional or ACU HQ seminars for information purposes.

Chief Marshal: will receive training and mentoring by the Clerk of the Course.

NB: an ACU Marshals Guidance booklet is available for reference purposes – please contact the ACU Track Racing Secretary for further information.

Marshal: will receive training and mentoring by the Clerk/Assistant Clerk of the Course or Chief Marshal.

NB: An ACU Marshals Guidance booklet is available for reference purpose together with additional relevant documentation to assist in the training and recording of the training of Marshals. The documentation is available by contacting the ACU Track Racing Secretary. A Marshal's registration card will be issued by the ACU after training has been given by the Clerk of the Course.

Medical Officer: must be a qualified Medical Practitioner or Paramedic – training for this Official is not supplied by the ACU. Qualification is only possible via the appropriate professional body.

Rider Liaison Officer: refer to note 4 below

All other Technical Officials, Race Day Officials (e.g. Secretary of the Meeting, Incident Officer, Club Stewards) and Marshals may be registered, free of any charge. All such Officials may or may not be required to attend a seminar; however the appointing organiser must at all times be in a position to demonstrate competency and training in respect of the individuals concerned. Registration will be renewed annually. Registered Officials and Marshals will receive an appropriate form of identification from the ACU.

Note 1 Incident Officer: will collate all information and documentation and prepare reports relating to serious accidents and to all incidents involving Officials or spectators. A Deputy Clerk of the Course may undertake these duties. An Incident Officer may be nominated to attend a Clerk of the Course seminar to assist with these duties.

Note 2 Secretary of the Meeting: will be responsible for all administration connected with the organisation of a race meeting.

Note 3 Club Stewards: will together with the Chief Steward, form the Judicial authority for the running and overseeing of the race meeting.

Note 4 Rider Liaison Officer: may be appointed to assist the Clerk of the Course. It is recommended that a Rider Liaison Officer should hold at least a Regional Clerk of the Course licence. It is also strongly recommended that a Rider Liaison Officer is appointed by the organising club when staging higher status events (e.g. National Championships/British Masters and International permitted events). In this situation the Rider Liaison Officer must hold an ACU National Clerk of the Course licence.

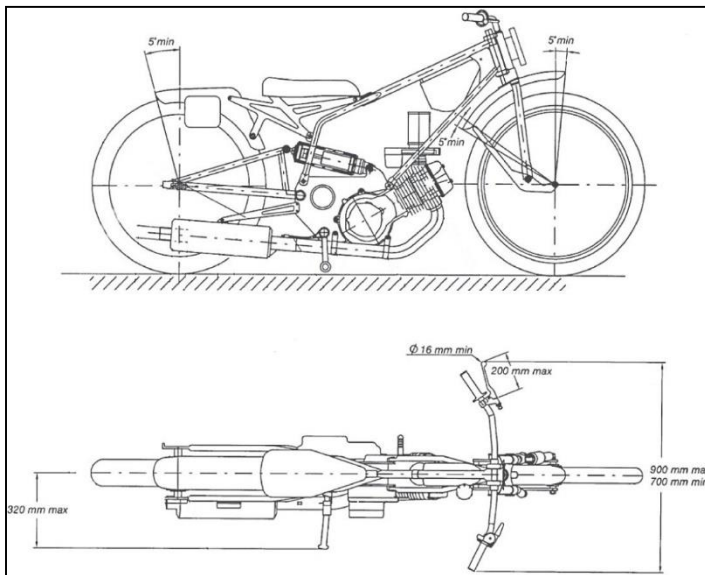

Figure 3: Track Racing Motorcycle

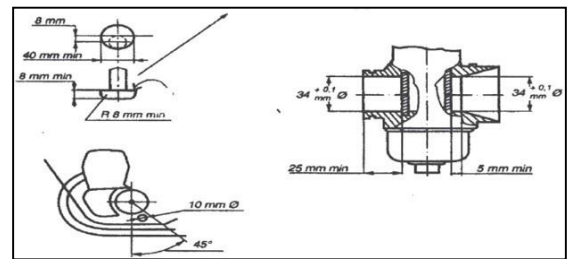

Figure 1: 500cc solo only

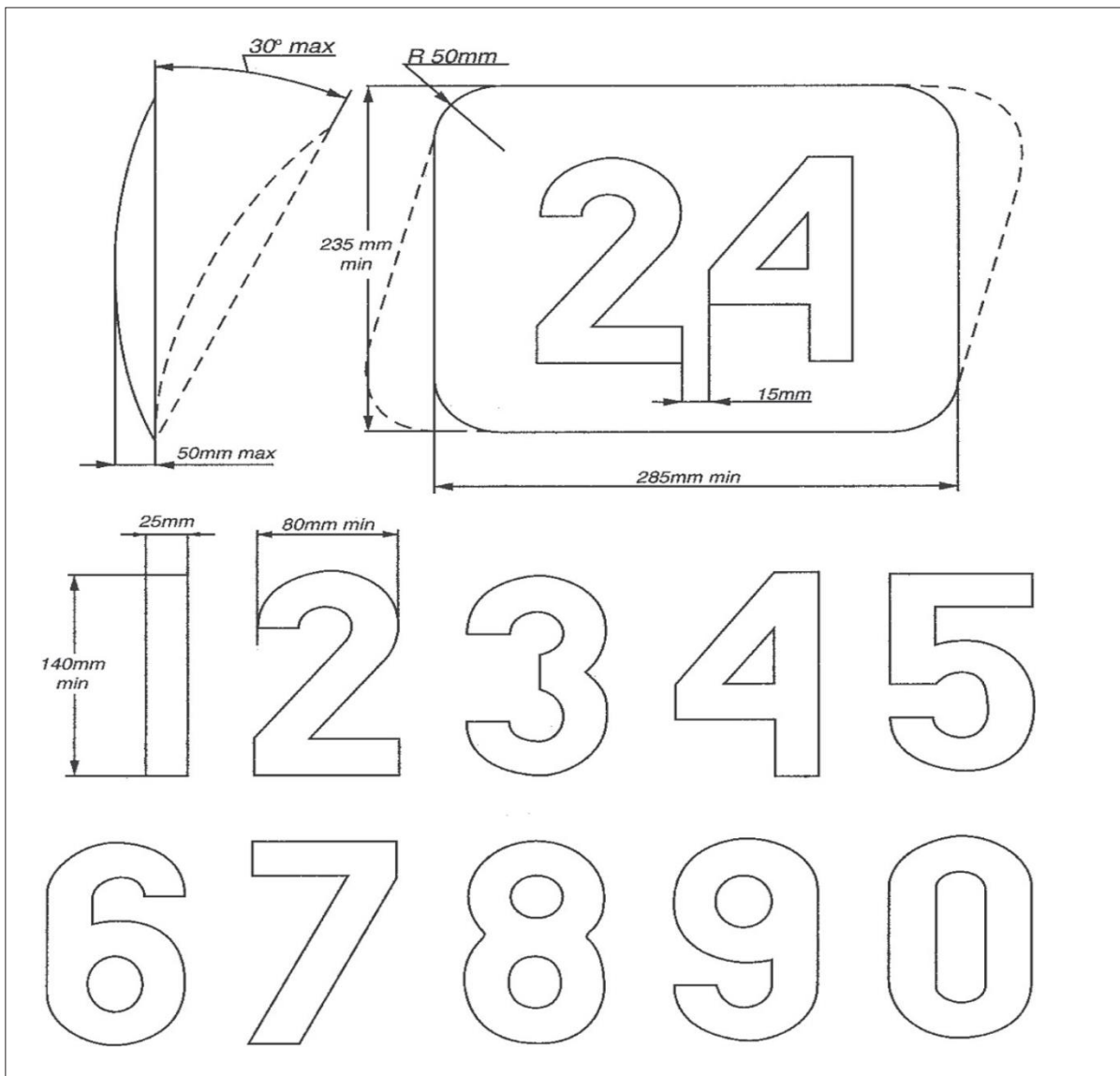

Figure 2: Numberplates