

# section two

**STANDING REGULATIONS**

# **Motocross**

## Standing Regulations

**SECTION 1 MEETINGS**

1.1	Definitions	<b>106</b>
1.2	Categories of Meetings	<b>106</b>
1.2.1	International	<b>106</b>
1.2.2	European Open	<b>106</b>
1.2.3	National	<b>106</b>
1.2.4	Open	<b>107</b>
1.2.5	Restricted	<b>107</b>
1.3	Supercross	<b>107</b>
1.4	Beachcross	<b>107</b>
1.5	Minibike	<b>107</b>
1.6	Eligibility of Foreign Riders in National, Open and Restricted Meetings	<b>107</b>
1.7	Practice Meetings and Test Days	<b>107</b>
1.8	Conditions for Motocross Meetings	<b>107</b>

**SECTION 2 ELIGIBILITY**

2.1	Licences	<b>108</b>
2.2	Capacity and Licence Restrictions	<b>109</b>
2.3	Youth	<b>110</b>
2.4	Adult	<b>111</b>
2.5	Physical Eligibility/Proficiency Assessment	<b>111</b>

**SECTION 3 CLASS VARIATIONS**

3.1	E4 Class	<b>111</b>
3.2	Automatic Class	<b>111</b>
3.3	65cc Junior Class	<b>112</b>
3.4	85cc Small Wheel and 85cc Big Wheel Classes	<b>112</b>
3.5	Youth 125cc	<b>112</b>
3.6	125/250F	<b>112</b>
3.7	MX2	<b>112</b>
3.8	MX1	<b>112</b>
3.9	Open (Adult)	<b>112</b>
3.10	Formula Classes	<b>112</b>
3.11	50cc/100cc Quad Class	<b>112</b>
3.12	150cc/250cc Quad Class	<b>112</b>

**SECTION 4 LICENCES AND REGISTRATIONS (OFFICIALS)**

4.1	Licensed Officials	<b>113</b>
4.1.1	Clerk of the Course/Race Director	<b>113</b>
4.1.2	Steward/Referee	<b>113</b>
4.1.3	Chief Technical Officer	<b>113</b>
4.1.4	Measurer	<b>114</b>
4.1.5	Timekeepers	<b>114</b>
4.2	Unlicensed Officials	<b>114</b>
4.2.1	Incident Officer	<b>114</b>
4.2.2	Secretary of the Meeting	<b>114</b>
4.2.3	Club Stewards	<b>114</b>
4.2.4	Marshal	<b>114</b>
4.2.5	Medical Officer	<b>115</b>

**SECTION 5 SPECIFICATION OF MOTORCYCLE**

5.1	Brakes	115
5.2	Tyres	115
5.3	Mudguards	115
5.4	Clutch and Brake Levers	115
5.5	Footrests and Handlebars	115
5.6	Lamps	115
5.7	Throttle	115
5.8	Exhaust Pipes	116
5.9	Running of Engines	116
5.10	Fuel	116
5.11	Ignition Cut-Out	116
5.12	Chain Guards	116
5.13	Construction	116
5.14	Wheels	116
5.15	Engines	117
5.16	Electric Motorcycles	117
5.17	Miscellaneous	119

**SECTION 6 NUMBER PLATES**

6.10	Number Plate Diagram	120
------	----------------------	-----

**SECTION 7 TECHNICAL CONTROL****SECTION 8 SAFETY**

8.1	Medical Services	122
8.2	Clothing	124
8.2.1	Motocross, Supercross and Beachcross	124
8.2.2	Minibike	124
8.3	Track Safety	124
8.4	Fire Extinguishers	124
8.5	Riding in the Paddock	125
8.6	Track Access	125
8.7	Flag Signals	125

**SECTION 9 RACE MANAGEMENT**

9.1	Entries	125
9.2	Practice	126
9.3	Start Positions	126
9.4	Electronic Timekeeping	126
9.5	Races	126
9.6	Method of Starting	126
9.7	Starter's Orders	126
9.8	False Starts	127
9.9	Stopping a Race	127
9.10	Finish of Race	127
9.11	Race Results	128
9.12	Change of Machine	128
9.13	Change of Sidecar Passenger	128
9.14	Outside Assistance	128
9.15	Foul, Unfair or Dangerous Riding	128

9.16	Course Conduct	<b>129</b>
9.17	Awards	<b>129</b>

**SECTION 10 GENERAL**

10.1	Instructions to Riders	<b>129</b>
10.2	Conduct	<b>129</b>
10.3	Parental Responsibility	<b>129</b>
10.4	Declaration	<b>129</b>
10.5	Compliance with Regulations	<b>129</b>
10.6	Dogs at Off Road Motorcycle Events	<b>129</b>

**SECTION 11 BEACHCROSS**

11.1	Specification of Motorcycle	<b>130</b>
11.2	LPG Fuel/Diesel	<b>130</b>
11.3	Circuit	<b>130</b>
11.4	Starter's Orders	<b>130</b>
11.5	Finish of a Race	<b>130</b>
11.6	Duration of a Race	<b>130</b>
11.7	Interruption of a Race	<b>130</b>
11.8	Disqualifications	<b>130</b>

**SECTION 12 CROSS COUNTRY QUADS STANDING REGULATIONS**

12.1	Meetings	<b>130</b>
12.2	Eligibility	<b>131</b>
12.3	Class Variations	<b>132</b>
12.4	Licences and Registrations (Officials)	<b>132</b>
12.5	Specification of a Motorcycle	<b>132</b>
12.6	Number Plates	<b>132</b>
12.7	Technical Control	<b>132</b>
12.8	Safety	<b>133</b>
12.9	Race Management	<b>133</b>
12.10	General	<b>135</b>

**SECTION 13 GRADING**

13.1	ACU Motocross Riders Expert Grading Scheme (Adult)	<b>135</b>
------	--	------------

**SECTION 14 MOTOCROSS MOTORCYCLE 136**

**The National Sporting Code of the ACU and the Standing Regulations together with the Supplementary Regulations and any Final Instructions shall apply to all Motocross Events held under an ACU Permit.**

## SECTION 1 MEETINGS

### 1.1 DEFINITIONS

- **FIM** – Fédération Internationale de Motorcyclisme – The international governing body of motorcycle sport
- **FIME** – Fédération Internationale de Motorcyclisme Europe – European governing body for motorcycle sport
- **FMN** – Federation Motorcycliste Nationale – FIM affiliated National federations
- **ACU** – Auto Cycle Union – The FMN of the FIM for the British Isles excluding Northern Ireland
- **SACU** – Scottish Auto Cycle Union
- **MCUI** – Motor Cycle Union of Ireland – The FMN of the FIM for Ireland
- **IMN** – International Meeting Number issued by the FIM

### 1.2 CATEGORIES OF MEETINGS

- Restricted Meetings
- Open Meetings
- National Meetings
- European Open Meetings
- International Meetings

#### 1.2.1 INTERNATIONAL

1. The Permit shall be issued by ACU Headquarters for a meeting inscribed on the International Calendar of the FIM and having an FIM International Meeting Number (IMN).
2. An International meeting is open to Entrants and Riders of more than one nation who must hold an International Licence or a National licence issued by the ACU, the SACU or their FMN valid for the particular meeting concerned.
3. All riders not holding a licence issued by the ACU or SACU must carry proof of Insurance and a written Start Permission document issued by their FMN.

**Note:** This includes all riders holding a licence issued by the MCUI.

#### 1.2.2 EUROPEAN OPEN

1. The permit shall be issued by ACU Headquarters for a meeting inscribed on the Calendar of the Fédération Internationale de Motorcyclisme Europe (FIME) and having a European Meeting Number (EMN).
2. A European Open meeting is open to Entrants and Riders of more than one European nation who must hold the appropriate Competition Licence valid for the particular meeting concerned.
3. All riders not holding a Licence issued by the ACU or SACU must carry proof of Insurance and a written Start Permission document issued by their FMN.

**Note:** This includes all riders holding a licence issued by the MCUI.

#### 1.2.3 NATIONAL

1. The Permit shall be issued by ACU Headquarters.
2. A National meeting is open to Entrants and Riders who are the holders of an ACU Motocross or International Motocross Licence issued by the ACU, SACU or any FMN valid for the particular meeting concerned.
3. All riders not holding a Licence issued by the ACU or SACU must carry proof of Insurance and a written Start Permission document issued by their FMN.

**Note:** This includes all riders holding a licence issued by the MCUI.

#### **1.2.4 OPEN**

1. The Permits for events run under basic insurance are issued by ACU Headquarters.
2. The Permits for events run under Premier insurance are issued by the Centre to which the club is affiliated.
3. An Open meeting is open to Entrants and Riders who are the holders of a Licence issued by the ACU, SACU or any FMN valid for the meeting concerned.
4. All riders not holding a Licence issued by the ACU or SACU must carry proof of Insurance and a written Start Permission document issued by their FMN.

**Note:** This includes all riders holding a licence issued by the MCUI.

#### **1.2.5 RESTRICTED**

1. The Permits for events run under basic insurance are issued by ACU Headquarters.
2. The Permits for events run under Premier insurance are issued by the Centre to which the club is affiliated.
3. A Restricted meeting is open to Entrants and Riders who are the holders of a current Licence issued by the ACU, SACU or any FMN valid for the meeting concerned.
4. The Supplementary Regulations issued for the event must specify all restrictions and requirements of eligibility.

**Note:** This includes all riders holding a licence issued by the MCUI.

#### **1.3 SUPERCROSS**

1. Arena/Supercross is defined as a motorcycle event conducted in a stadium type facility, open or fully closed, using Motocross motorcycles.
2. The permits for Supercross events are issued by ACU Headquarters.
3. Supercross events may be run under any of the above categories.

#### **1.4 BEACHCROSS**

1. The permits for Beachcross are issued by ACU Headquarters.
2. Beachcross events may be run under any of the above categories.

#### **1.5 MINIBIKE**

1. The permits for Minibike events are issued by ACU Headquarters.
2. Minibike events may be run under any of the above categories.

#### **1.6 ELIGIBILITY OF FOREIGN RIDERS IN NATIONAL, OPEN AND RESTRICTED MEETINGS**

1. The Supplementary Regulations issued for the event must specify the licence qualification and eligibility requirements of foreign riders.
2. All riders must have a current Licence and Start Permission from their own Federation valid for the event.

#### **1.7 PRACTICE MEETINGS AND TEST DAYS**

1. Permits for Practice Meetings and Test Days may be issued on application to ACU Headquarters. (Please request a copy of the Practice Permit Guidelines from the ACU Head Office when applying for this type of permit)
2. No such event may be held unless the appropriate Permit and Insurance has been issued.

#### **1.8 CONDITIONS FOR MOTOCROSS MEETINGS**

1. The organiser must be affiliated or approved by the ACU.
2. The venue must hold a current Track Certificate issued by the ACU.

3. The permit issuing authority must approve the Supplementary Regulations for the event and issue an ACU Permit prior to publication and circulation. Applications should be made a least six weeks prior to the meeting date.
4. The race office must remain operative with all equipment in place until the end of the period provided for the lodging of a protest or appeal, and all officials and marshals must remain at the circuit and available to the Clerk of the Course and the Stewards during that period.

## SECTION 2 ELIGIBILITY

### 2.1 LICENCES

1. For National competitions, entrants, riders and passengers must hold a current competition licence for International or National events issued by the Auto Cycle Union, Scottish Auto Cycle Union or any FMN.
2. For all competitions of below National status, a current competition licence is required.
3. Day Licences. A One Event Competition Licence grants the same benefits of an annual licence for the duration of one event only and is available for Motocross, Supercross, Beachcross or Minibike events up to and including National status.
4. Riders in possession of a Motocross Dual (youth open/adult MX) licence may compete in either Youth or Adult motocross events. Riders must choose the class at the time of entry as it is not permitted to compete on both Youth and adults races at one meeting. (This is not applicable to Supercross).
5. Details of eligibility will be found in the Supplementary Regulations of the event.
6. Youth only: All new applications must be accompanied by a photocopy of the rider's birth certificate.

#### Youth Solo

Age on 1 Jan	Grade	Engine Capacity	Wheel Size/ Specification
4-7 years	E4	Electric max 1.5kw output	10 inch rear, 10 inch front
6-7 years 6-8 years	Automatic	Minimum 49cc 2 or 4 stroke. Maximum 50cc 2 or 4 stroke single speed automatic, no manual clutch	Maximum 12 inch rear, 15 inch front
7-10 years	65cc Junior	Minimum 60cc 2 stroke or 85cc 4 stroke. Maximum 65cc 2 stroke or 110cc 4 stroke	12 inch rear, 14 inch front
9-12 years	85cc Small Wheel, Intermediate	Minimum 70cc 2 stroke or 125cc 4 stroke. Manual clutch, maximum 85cc 2 stroke or 150cc 4 stroke	14 inch rear, 17 inch front
11-14 years	85cc Big Wheel, Senior	Minimum 70cc 2 stroke or 125cc 4 stroke. Manual clutch, maximum 85cc 2 stroke or 150cc 4 stroke	16 inch rear, 19 inch front
13-17 years	125cc	Minimum 120cc 2 stroke maximum 125cc 2 stroke, manual clutch	19 inch rear, 21 inch front
14-17 years	125/250f	Minimum 120cc 2 stroke or 175cc 4 stroke. Maximum 150cc 2 stroke or 250cc 4 stroke. Manual clutch.	19 inch rear, 21 inch front

Youth Solo Riders may continue in the youth 125/250f class until the end of the year in which their 18th birthday falls.



## 2.2 CAPACITY AND LICENCE RESTRICTIONS

### Adult Solo

Age on 1 Jan	Engine Capacity
15 years	Minimum 120cc up to maximum 650cc 2 stroke Minimum 175cc up to maximum 650cc 4 stroke Electric powered machines with an output of up to 16kw (22hp) measured at the rear wheel

### Sidocar

Age on 1 Jan	Grade	Specification
15 years	Driver	Over 350cc and up to 1000cc 4 stroke and up to 750cc 2 stroke
15 years	Passenger	

### Adult Quad

15 years		Up to 550cc max 2 cylinders 2 stroke
15 years		Up to 800cc 4 stroke max 1 cylinder

### Youth Quad

Max cc	Age	Type	Specification
50cc (Y1)	7–9 Yrs	Automatic Quad	Performance Modifications are allowed up to a maximum of 50cc. Engine must not exceed 50cc at time of Manufacture.
100cc Auto (Y2)	8–13 Yrs	Auto, 100cc Production Quads built by the manufacturer	Engine must not have exceeded 100cc 2 Stroke Auto/150cc 4 Stroke Auto
100cc Open (Y2)	9–13 yrs	Open Geared Class Max 100cc 2 Stroke/150cc 4 Stroke	Engine must not have exceeded 119cc 2 Stroke/179cc 4 Stroke.
150cc Open 2–150 (Y3)	11–16 Yrs	Open Geared Class Max 100cc 2 Stroke Air Cooled/150cc 4 Stroke Water Cooled	Engine must not exceed 119cc 2 Stroke/179cc 4 Stroke. 150cc Open 2 Class compete in the 250cc Race Group
250cc Air Cooled (Y3)	11–16 Yrs	Air Cooled Production Quads	Performance Modifications are allowed to the Engine & chassis up to a maximum of 239cc 2 Stroke/299cc 4 Stroke. Frame & Engine must be by the original Manufacturer. Engine must not exceed 239cc 2 stroke/299cc 4 Stroke
250cc Open (Y4)	14–17 Yrs	Open Class (Hybrids allowed)	Engine must not exceed 239cc 2 stroke/299cc 4 Stroke

No Engine displacement reductions are allowed (sleeved down bigger engines to fit the cc criteria are not allowed)

**Adult Mini Bike**

Age on 1 Jan	Grade	Specification
15 years	Pro 88cc	Minibike open cradle frame, 4 stroke, horizontal engine upto 88cc, Semi Auto (no Manual Clutch) max wheel size 12" front 10" rear. Axle to axle measurement must not exceed 1150mm and maximum height Floor/Seat 750mm
15 years	Stock 110cc	Minibike open cradle frame, 4 stroke, horizontal engine upto 112cc, Semi Auto (no Manual Clutch) 20mm Carburettor, 2 valve only, Aframe Rear Swing Arm (none Mx Type) Telescopic Conventional Fork (none Inverted) max wheel size 14" front 12" rear. Axle to axle measurement must not exceed 1150mm and maximum height Floor/Seat 750mm
15 years	Pro 160cc	Minibike open cradle frame, 4 stroke, horizontal engine upto 160cc max wheel size 14" front 12" rear. Axle to axle measurement must not exceed 1210mm and maximum height Floor/Seat 840mm
21 years	Open	Minibike open cradle frame, 4 stroke, horizontal engine upto 212cc max wheel size 14" front 12" rear. Axle to axle measurement must not exceed 1210mm and maximum height Floor/Seat 840mm

**Youth Mini Bike**

Age on 1 Jan	Grade	Specification
6–8 years	Youth 50cc	Any 50cc off road bike 2 stroke or 4 stroke, horizontal or vertical engine, max wheel size 14" front 12" rear.
9–14 years	Youth 140cc	Minibike open cradle frame, 4 stroke, horizontal engine upto 140cc max wheel size 14" front and 12" rear. Axle to axle measurement must not exceed 1210mm and maximum height Floor/Seat 840mm

After reaching 15 years of age riders can apply for an adult solo Motocross licence and still retain a youth open licence until the end of the year in which their 18th birthday falls.

After reaching 15 years of age riders can apply for an adult quad Motocross licence and still retain a 250 youth licence until the end of the year in which their 18th birthday falls. (See 2.2 Capacity and Licence Restrictions).

**2.3 YOUTH**

1. Within the above limits youth riders will compete during the 2020 season in classes determined by date of birth. Riders may ride in a lower class for experience on a non-award basis.
2. No rider may compete before his/her fourth birthday.
3. When a rider reaches the maximum age limit for his/her group, he/she may continue to compete in that group until the end of the calendar year.
4. On reaching the minimum age for the next group, the rider may upgrade. Please note that any rider who chooses to upgrade cannot then move back to the lower capacity class once they have competed at the higher level. (With the exception of competing in the British MX2 or Supercross Championships).
5. Any rider upgrading before the required minimum age is reached will be subject to disciplinary action unless officially upgraded by the Motocross Department.
6. An assessment will be required for any rider wishing to ride in a class of which they do not

reach the age requirement to be arranged by the rider following application to the ACU Motocross Department.

7. The parent or legal guardian must accompany a youth competitor under the age of 18 to any meeting and stay for the entire duration of the time that the rider is present.
8. Riders in possession of a Motocross Dual (youth open/adult MX) licence may compete in either youth or adult motocross events. Riders in possession of an ATV/Quad Dual (youth 250cc Adult Quad) licence may compete in either youth or adult motocross events. Riders must choose the class at the time of entry as it is not permitted to compete in both Youth and adults races at one meeting. (This is not applicable to Supercross)

#### **2.4 ADULT**

1. The parent or legal guardian must accompany a youth competitor under the age of 18 to any meeting and stay for the entire duration of the time that the rider is present.
2. No rider will be permitted to compete in the adult classes until they reach the minimum required age and hold the correct licence.

#### **2.5 PHYSICAL ELIGIBILITY/PROFICIENCY ASSESSMENT**

All youth riders should be able to sit astride their machines and with one foot firmly on the ground must be able to control the gear lever or the foot brake with the other foot.

### **SECTION 3 CLASS VARIATIONS**

#### **3.1 E4 CLASS**

1. Clubs may not run the E4 class with any other class.
2. Parental persons must be signed on and wearing an appropriate identification bib or sash before entering any part of the course to assist their or any other rider. They are permitted to hold the rear of the machine immediately prior to the start of the race.

#### **3 CIRCUIT**

If being run on the full MX circuit the E4 class route must be clearly marked and risk assessed. If being run on a separate circuit located at the venue, then the Area/Circuit must be risk assessed and be no longer than 400m. and must be approved on the day by the Event steward or Clerk of the Course.

All other requirements under Motocross SRs such as officials, medical cover, protective clothing, helmets apply

#### **4 RACES**

Race lengths must not exceed 7 minutes. No mass starts. Maximum of 15 riders allowed to start in any one race

#### **5 NON-SPEED EVENTS**

All races will be considered as non-speed events although permitted by a motocross permit

#### **3.2 AUTOMATIC CLASS**

1. Clubs may run the Auto and Junior classes together. Electric machines with a maximum output of 8kw are only allowed in the auto class
2. Where there is direct conflict between large and small machines, clubs at their discretion may separate them into two classes.
3. Parental persons must be signed on and wearing an appropriate identification bib or sash before entering any part of the course to assist their or any other rider. They are permitted to hold the rear of the machine immediately prior to the start of the race.

**3.3 65CC JUNIOR CLASS**

Clubs may run the Junior 65cc and Auto classes together. Electric machines with a maximum output of 10kw are only allowed in the 65cc junior class.

**3.4 85CC SMALL WHEEL AND 85CC BIG WHEEL CLASSES**

Clubs may run 85cc Small Wheel and 85cc Big Wheel together.

**3.5 YOUTH 125CC**

Clubs may run the youth 125cc class and 125/250f class together. The 125cc class is not permitted to run in a joint class with any other classes or adult competitors. Clubs must stipulate in the event SRs if these two classes are run together or scored individually.

**3.6 125/250F**

The 125/250f Open Class may run with the 125cc class. The 125/250f Open Class may run with an adult class. Clubs must stipulate in the event SRs if these two classes are run together and must be scored individually.

**3.7 MX2**

120cc to 250cc twostroke or 175cc to 250cc fourstroke. Clubs may specify capacity restrictions for Championships within their event Supplementary Regulations. Electric machines with a maximum output of 16kw are only allowed in the MX2 class.

**3.8 MX1**

Over 175cc to 500cc twostroke or 251cc to 450cc fourstroke. Clubs may specify capacity restrictions for Championships within their event Supplementary Regulations.

**3.9 OPEN (ADULT)**

All solo machines 120cc twostroke or 175cc fourstroke up to 650cc two or fourstroke.

**3.10 FORMULA CLASSES**

For older machines can also be catered for at events i.e. pre-65, pre-75, twinshock, Evo (up to and including 1989) Super Evo (1990–1996).

**3.11 50CC/100CC QUAD CLASS**

50cc Quad class may be run with the 100cc Quad Classes but will not be permitted to run in a joint class with any other class. (Y1 & Y2)

**3.12 150CC/250CC QUAD CLASS**

150cc Quad class may be run with 250cc Quad Classes but will not be permitted to run in a joint class with any other class. (Y3 & Y4)

## SECTION 4 LICENCES AND REGISTRATIONS (OFFICIALS)

Motocross Race Officials are required to hold an ACU Licence of the appropriate grade for the performance of their duties. The minimum age for motocross licensed officials is 18 years. Licences for officials will be issued free of charge.

### 4.1 LICENSED OFFICIALS

Motocross, Supercross, Beachcross and Minibike Officials who require a Licence.

	See Note Below	Licence Required	Attendance at Seminar/ Training Session
Clerk of the Course	1	YES	3 YEARS Every Third Year maximum
Race Director	National Only	YES	3 YEARS Every Third year maximum
Steward/Referee	2	YES	3 YEARS Every Third Year maximum
Chief Technical Officer	3	YES	3 YEARS Every Third Year maximum
Sound Inspector		YES	3 YEARS Every Third Year maximum
Measurer	4	YES	3 YEARS Every Third Year maximum
Timekeeper	5	YES	By Assessment

Clubs and Centres shall only nominate candidates whose aptitude and integrity for the position they can fully justify. Official ACU approval and the issue of a Licence is only after the candidates have proved to be competent according to the special requirements for each discipline. The respective Committees and Panels organise seminars that are compulsory for certain officials. A Licence, obtained following the successful completion of a seminar, is valid for 3 years.

#### 4.1.1 CLERK OF THE COURSE/RACE DIRECTOR

- DEFINITION.** Refer to the National Sporting Code.
- AGE LIMITS.** There are no upper age limits for Motocross Clerks of the Course of all grades. A Clerk of the Course must be physically able to reach all parts of the circuit to carry out his or her duties.
- GRADES – Motocross/Supercross:**
  - National.** A Clerk of the Course who may officiate at any event held under an ACU permit. May officiate as Deputy or Assistant to an FIM International Clerk of the Course.
  - Regional.** A Clerk of the Course who may officiate at any event held under an Open or Restricted Permit.
- Upgrading.** To upgrade from Regional to National an official must have the recommendation of their club, centre or region or be recommended by the Motocross Committee.

#### 4.1.2 STEWARD/REFEREE

- DEFINITION.** Refer to the National Sporting Code.
- GRADES**
  - There are two grades of licence for a Steward at Motocross events, National or Regional.
  - There is one grade of licence for a Referee at Supercross events, National.
- AGE LIMITS.** There is no upper age limit for Stewards/Referees at Motocross events. A Steward/Referee must be capable of inspecting the entire circuit without assistance prior to the event starting. (A Steward could use an ATV for this purpose in Motocross).

#### 4.1.3 CHIEF TECHNICAL OFFICER

- The Chief Technical Officer will be licensed by the Technical Department to be in charge of the technical control at an event. The Technical Department may restrict the disciplines of licence holders.

- A regional Technical Officer will be trained in a centre or region but will be registered through the ACU at Rugby and may take charge of a meeting of below National status.

#### 4.1.4 MEASURER

The licence is issued by the ACU Technical Department and may be restricted by discipline.

#### 4.1.5 TIMEKEEPERS

Timekeepers will be required to renew their Licence every three years.

### 4.2 UNLICENSED OFFICIALS

Motocross, Supercross, Beachcross and Minibike Officials who do not require a Licence.

Officials	Notes	Attendance at Seminar/Training Session
Incident Officer	1	None required
Secretary of the Meeting	2	Will receive training at events receive instruction from the Clerk of the Course
Technical Official		Will receive training via a Chief Technical Officer at meetings.
Club Stewards	3	May attend Regional or ACU HQ Seminars for information purposes
Chief Marshal		May receive training at ACU HQ or Regional Training Days
Marshal	4	May receive training at Regional Training Days and at meetings via the Chief Marshal.
Medical Officer	5	None required

- All other Technical Officials, Race Day Officials (e.g. Secretary of the Meeting, Incident Officer, Club Stewards) and Marshals may be registered, free of any charge. All such Officials may or may not be required to attend a Seminar. Registration will be renewed annually. Registered Officials and Marshals will receive an appropriate form of identification from the ACU.
- All assistant officials whose function is to be carried out at the immediate trackside must be at least 16 years of age.
- All assistant officials who are under 18 years of age must have obtained parental agreement to carry out the duty and the signing on signature must be countersigned by someone who is responsible for the official at the event.
- When using the services of minors (persons under 18 years of age) for any official duties at any event special attention must be given to any risks which may be associated with the duty, and to the previous experience of the official.

#### 4.2.1 INCIDENT OFFICER

- Will collate all information and documentation, and prepare reports relating to serious accidents and to all incidents involving Officials or Spectators.
- A Deputy Clerk of the Course may undertake these duties. An Incident Officer may be nominated to attend a Clerk of the Course Seminar as part of their training.

#### 4.2.2 SECRETARY OF THE MEETING

Will be responsible for all administration connected with the organisation of a meeting.

#### 4.2.3 CLUB STEWARDS

Will together with the Chief Steward form the judicial authority over the running of the meeting.

#### 4.2.4 MARSHAL

- All Assistant Officials or Marshals whose function is to be carried out immediate trackside must be at least 16 years of age with the exception of Marshals who are in membership of a

recognized military corps who must be at least 14 years of age. All Marshals who are under 18 years of age must have obtained parental agreement to carry out the duty and the signing on signature must be countersigned by someone who is responsible for the official at the event.

2. Flag Marshals must be provided with a tabard/waistcoat clearly identifiable.

#### **4.2.5 MEDICAL OFFICER**

See medical section of ACU Handbook.

## **SECTION 5 SPECIFICATION OF MOTORCYCLE**

(CATEGORY 1) All Motorcycles in group A1 (Solo), B1 (Sidecar) and G (Quad) shall comply with the National Sporting Code Appendix D and the following:

### **5.1 BRAKES**

1. Motorcycles must be equipped with one efficient brake operating on each wheel and be operated independently from the driving position.
2. For B1 (Sidecar) motorcycles brakes are not required on the sidecar wheel.
3. For group G (Quad) motorcycles brakes must be capable of operating, as a minimum, to both rear wheels.

### **5.2 TYRES**

1. There is no restriction as to the tyres that may be used other than as may be laid down in the Supplementary Regulations but chains and other non-skid devices will not be permitted.
2. Scoop or paddle (continuous radial rib) tyres and/or tyres with lugs having a height of more than 9.5mm are forbidden.

### **5.3 MUDGUARDS**

Category A (Solo) and B (Sidecar) motorcycles must be fitted with two mudguards giving protection to the driver. The rear mudguard must cover 35 degrees of the upper rear wheel.

### **5.4 CLUTCH AND BRAKE LEVERS**

1. Clutch and brake levers must be, in principal, ball ended, the diameter of the ball to be at least 12.5mm.
2. This ball can also be flattened but in any case the edges must be rounded.
3. These ball ends must be permanently fixed to form an integral part of the lever.

### **5.5 FOOTRESTS AND HANDLEBARS**

The ends of the footrests must be rounded with a radius of not less than 8mm. The ends of the handlebars on all motorcycles shall be rounded or otherwise protected. Handlebars must be equipped with a protection pad on the cross bar. The handlebars without cross member must be equipped with a protection pad located in the middle of the handlebars, covering widely the handlebars clamps. For group G (Quad) motorcycles nerf bars must be fitted.

### **5.6 LAMPS**

1. For motorcycles group A1 (Solo) and B1 (Sidecar) lamps, registration plates and licence holders must be removed.
2. For motorcycles group G (Quad) direction indicators and mirrors must be removed. Other glass or plastic lenses must be taped, padded with foam rubber, or equivalent, at least 25mm thick and taped again.

### **5.7 THROTTLE**

All machines must be fitted with self-closing throttles.

**5.8 EXHAUST PIPES**

1. The end of the exhaust pipe or pipes must not project beyond any part of the vehicle or its bodywork.
2. Exhaust gasses must not be discharged so as to raise dust or foul the tyres or brakes or inconvenience a following driver.
3. A provision for the discharge of waste or surplus oil must be made so that it is collected and not spill onto the circuit.
4. Breathers can be routed into air boxes or collector tanks.

**5.9 RUNNING OF ENGINES**

1. The running of engines is prohibited except during official practice, actual racing, sound testing and for a period not exceeding five minutes prior to the start of each race.
2. A breach of this regulation may involve disqualification from the meeting of the rider of the motorcycle concerned.

**5.10 FUEL**

For Fuel specifications please refer to Fuel Regulations section of the ACU Handbook.

**5.11 IGNITION CUT-OUT**

1. Motorcycles in group A1 (Solo) used in Motocross will be fitted with an engine cut-out button.
2. Motorcycles used in group B1 (Sidecar) will be fitted with an engine cut out button that must be operated by a non elastic string or cord (coil telephone wire is not permitted). The cord should be a maximum of 500mm. Any part of the cut-out that remains live when disconnected must be shrouded in order to prevent accidental contact with any part of the motorcycle.
3. Motorcycles in group G (Quad) will be fitted with an engine cut out button that must be operated by a non elastic string or cord. Any part of the cut-out that remains live when disconnected must be shrouded in order to prevent accidental contact with any part of the motorcycle.

**5.12 CHAIN GUARDS**

1. For motorcycles group A1 (Solo) and B1 (Sidecar) the manufacturer's original guards or parts of similar design must remain in place. However machines pre 2000 may be exempt from this rule. See national Sporting Code.
2. For group G (Quad) motorcycles an adequate guard must be fitted to prevent any accidental contact with the primary chain or any part of the run not in contact with the sprocket. See National Sporting Code.

**5.13 CONSTRUCTION**

The use of titanium alloy nuts and bolts is allowed. But a dimension increase may be necessary when non-ferrous fasteners replace ferrous fasteners.

**5.14 WHEELS**

1. For all groups wheels with six or less spokes must be guarded.
2. For motorcycles group B1 (Sidecar)
  - a. The three wheels shall each be of at least 400mm (16") in diameter measured over the outside of the tyre.
  - b. The wheel track, or lateral distance between tracks, shall be no more than 1150mm.
3. For motorcycles group G (Quad) the measurement from the front wheel to its following rear wheel must be equal.
4. Titanium Spindles are not allowed.



### 5.15 ENGINES

For motorcycles group G (Quad)

1. The engine must drive either or both rear wheels and must drive both rear wheels when competing against quads.
2. The engine must be behind the front wheel(s) and central in front of a line between the rear wheel centres.

### 5.16 ELECTRIC MOTOCYCLES

1. The technical concept is reserved for motorcycles propelled by non-thermal energies with zero toxic/noxious emissions and by the action of one wheel in contact with the ground. Amendments to these technical regulations may be made at any time in order to ensure fair competitions.
2. Two and/or three wheeled electric propelled machines, powered solely by stored electricity (battery/accumulator). The number of electric motors is limited to two.
3. E4 Class – An electric motor with a maximum output of up to approximately 1.5 kw measured at the back wheel  
Automatic class – An electric motor with a maximum output of up to 8 kw measured at the back wheel  
65cc Class – An electric motor with a maximum output of up to 12 kw measured at the back wheel  
MX2 Class – An electric motor with a maximum output of up to 16 kw measured at the back wheel
4. The charging system must be separate from the machine and comply with all electrical safety requirements including thermal overload trip, fusing and be equipped with an earth leakage protection breaker.
5. The Technical Steward shall check both the machine and the rider for compliance with the technical specifications, as well as the employment of good engineering construction practice, and the presence of adequate electrical insulation and weatherproofing.
6. All motorcycles must comply in every respect with all the requirements for racing as specified in the ACU General Technical Specifications, unless otherwise specified below.

#### Chain/Belt Guards

Chain/Belt Guards must be fitted to prevent any accidental contact with the primary chain/belt as a safety measure. The chain/belt guard must be fitted to protect the front and rear sprockets

#### Number Plates and Colours

See SR 6.9.

Colours: Green background – yellow numbers.

#### Machine Weight

E4 class Minimum weight: 30kg. The maximum weight limit shall not exceed 40kg.

Automatic Class Minimum weight: 30kg. The maximum weight limit shall not exceed 40kg.

65cc Class Minimum weight: 50kg. The maximum weight limit shall not exceed 60kg.

MX2 Class Minimum weight: 75kg. The maximum weight limit shall not exceed 120kg.

#### Accumulator (storage battery)

The accumulator is defined as any equipment used for the intermediate storage of electrical energy supplied by the charging unit. Any on-board accumulator is considered as an integral part of the vehicle's accumulator.

The type, dimensions and weight of accumulator/s cannot be changed between official practices and race.

All on-board electrical equipment, unless consisting of items originally powered by dry batteries, small accumulators or their own solar cells, must receive its energy supply from the vehicle's official accumulators.

IMPORTANT: As a condition of entry, a Material Data Safety Sheet must be supplied with

the race entry for the machine, including all relevant details as to the accumulator chemistry, human and environmental hazards, handling and specific fire risks and precautions.

### **Energy recovery**

Recovering energy generated by the kinetic energy of the vehicle is permitted.

### **Use of outside energy sources**

The use of any carbon based source of energy in any form whatsoever with the aim of improving the performance of the vehicle is strictly prohibited. This includes the energy used to drive the vehicle's cooling system.

### **Inclination**

It must be possible for a motorcycle, not being loaded, to be inclined to an angle of 40° from the vertical, without any part of it other than the tyre coming into contact with the ground. In race conditioned the motorcycle must be capable of affecting a standing start on an uphill slope with a gradient of 18%.

### **IEC Publications (Guidelines)**

If no specific rule exists in these Technical Rules, the relevant IEC Standard (International Electro-technical Commission Standard) or Report has to be observed:

- a) IEC 60529 Degrees of protection provided by enclosures (IP Code).
- b) IEC 60783 Wiring and connectors for the road vehicles. This report is applicable to cabling and connectors used in battery electric road vehicles.
- c) IEC 60784 Instruments for electric road vehicles. This report is applicable to the instrumentation of electric road vehicles, excluding those items which are used as instrumentation in vehicles with internal combustion engines.
- d) IEC 60785 Rotating machines for electric road vehicles. This report is applicable to rotating electrical machines [traction motors and auxiliary motors] of electric road vehicles including hybrids, which are fed from the main traction batteries).
- e) IEC60786 Controllers for electric road vehicles. This report is applicable to the equipment on electric vehicles that control the rate of energy transfer between the traction battery or batteries and the motor or motors).

### **Operating Voltage**

The voltage is limited to 500 volts nominal between two points (ie. higher charging voltages are permitted).

### **Propulsion system failure**

The vehicle must be able to freewheel in the event that the propulsion system has stopped (i.e. fuel/charge exhausted or system failure).

### **General circuit breaker – 'Emergency Stop'**

Two emergency stop switches (circuit breakers/Kill switch) are required as a stop has to be easily accessible both to the rider and to marshals.

When seated in a normal riding position, the rider must be capable of interrupting all electrical transmission between the accumulators and the energy consumers by means of a spark-proof general circuit breaker/kill switch situated in front of him. This breaker must be located in such a way that it can be also operated from outside the vehicle.

This breaker must be clearly identified as such.

The use of a lanyard attached to the rider to operate this breaker/switch as an alternative to a button is recommended.

The general circuit must also include a second general circuit breaker/kill switch which When the motorcycle is in powered on state, there must be a clear visual indicator showing on the rear of the machine. This must be a flashing red light mounted on the rear bodywork and be visible from at least 10 metres away, from the side or rear. The light must flash between 1 and 2 times/second on a 50% duty cycle.

### **Power control**

A 'self-closing' throttle (power control) must be applied.

**5.17 MISCELLANEOUS**

1. For motorcycles group B1 (Sidecar) a passenger must be carried in addition to the driver.
2. Provision for the riders seat must be forward of a line between the rear wheel centres and above and/or behind the engine, to give the rider, when seated, full and safe control of the machine.
3. For motorcycles group G (Quad) bumpers and nerf bars must have all corners with a radius of a minimum of 12.5mm.

**SECTION 6 NUMBER PLATES**

1. Number plates will be a minimum of three in number on all machines and it is the rider's responsibility to ensure that the numbers are clearly visible.
2. No metallic or reflective colours may be used in any circumstances.
3. Plates and numbers must comply with the following requirements.
  - a) They must be made of a rigid material and solidly constructed.
  - b) The front plate should measure a minimum of 285mm × 235mm in size with a minimum of 50mm radius rounded corners.
  - c) The plates must be flat or slightly curved (not more that 25mm (1") from the true plane) and must not be otherwise bent or obscured in any way.
  - d) The front plate may be perforated but on no account may the numbers be perforated.
4. One plate must be carried facing forward and not more than 30 degrees from the vertical with one on each side of the machine.
5. Side number plates must be positioned above a horizontal line drawn through the rear spindle and behind a line drawn vertically at a minimum distance of 200mm behind the footrest. The size will be as accepted by the FIM.
6. The minimum dimensions of the front number plate numbers should be: height 140mm (5%), width 80mm (3%), width of stroke 25mm (1") and the space between any two figures 15mm (%). The minimum dimension of the side number plate numbers will be 100mm.
7. The Clerk of the Course has the discretion to disqualify any rider not showing legible numbers or discounting any appeal resulting from illegible numbers.
8. For motorcycles group G (Quad) a third number plate must be fitted with a minimum size of 150mm × 150mm mounted behind the rider on the rear grab bar, and be in line with the machine reading left to right on both sides. The mounting bracket must not be higher than 150mm. Height of the number 100mm. Width of the number 80mm. Width of stroke 25mm. Space between two numbers 15mm.
9. The colours shall be as follows: The figures and background must be in a 'matt' (non-shiny) colour.

**Front & Side Plates**

**Background Colour**

**Number Colour**

**Adult**

100cc to 145cc 2 stroke/125cc – 250cc 4 stroke	Black	White
146cc – 650cc 2 Stroke/251cc – 650cc 4 stroke	White	Black
Electric	Green	Yellow
Sidecars	Yellow	Black
Quads	White	Black

**Youth – Solo**

Electric Youth	Green	Yellow
Automatic – 65cc Junior	Black	White
85cc Small Wheel (Intermediate)	Red	White
85cc Big Wheel (Senior)	Green	White
125cc	Blue	White
125/250f	Black	White

**Youth – Quads**

50cc (Y1)	White	Black
100cc Auto (Y2)	Blue	White
100cc Open (Y2)	Red	White
150cc Open 2–150 (Y3)	White	Black
250cc Air Cooled (Y3)	Blue	White
250cc Open (Y4)	Red	White

**Minibike Adult**

Pro 88	White	Black
Stock 110	Blue	White
Pro 160	Green	Black
Open	TBA	TBA

**Mini Bike Youth**

50cc	Black	White
140cc	White	Black

Any other number plate or any marking on the motorcycle that might be confused with a number plate must be removed before the rider is allowed to start.

The only exception to the number plate regulations will be where special conditions apply to a National, Centre or Club Championship series and are explained in the Supplementary Regulations or conditions to that series.

Numbers for minibike racing must not exceed 2 digits, (i.e. 1–99)

**6.10 NUMBER PLATE DIAGRAM**

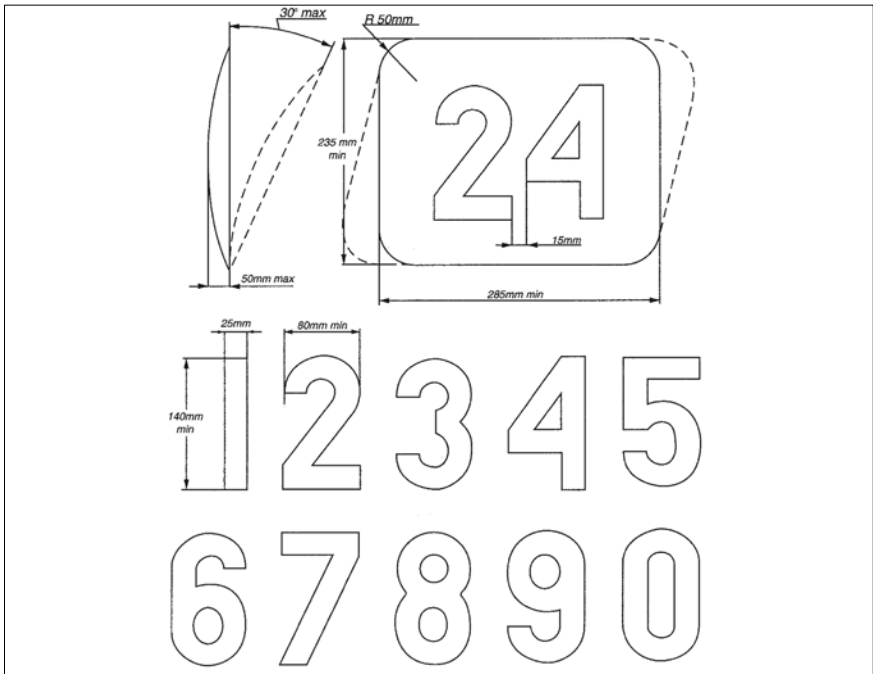

## SECTION 7 TECHNICAL CONTROL

1. All motorcycles, helmets and protective clothing must be presented to the Technical Officer as requested, for examination before the start of any practice or at any time during the meeting as may be required by the Clerk of the Course to ensure that they comply with the requirements of the regulations.
2. Any machine damaged in an incident can be recalled by the Technical Officer for re-inspection before being ridden again at the meeting.
3. Any bike fitted with additional side panels or streamlining must have such panels removed when presented for a noise test.
4. Every motorcycle finishing in a race must, if so required, be submitted for final examination and any motorcycle may be retained by the promoters for such a period as may be reasonably necessary for its examination.
5. Where it may be necessary for promoters to verify any fact, this shall be carried out at the cost of the rider. If a rider refuses to release his machine to be measured by the officials of the meeting than this action will result in automatic disqualification from the event.
6. In the event of a protest against machine specification where an engine has to be stripped an additional fee of £250 for four stroke and £150 for two stroke machines MUST be submitted with the protest and protest fee. In the event of the protest being upheld the additional fee will be returned. If the protest is not upheld the additional fee will be awarded to the other party and will be the only costs payable.
7. Sound Level Control:  
Two tests will be in operation.
  1. Static Test – For all machines pre 2010.
  2. The FIM 2 Metre Max Test – For machines post 2011.

### Solo

- For machines 2013 and onwards – maximum sound limit 112dB/A (+2 dB/A before each race, +3 dB/A after the race) tested using the 2 Metre Max method. Type 1 and Type 2 meters.
- For 2010–2012 machines – maximum sound limit 115 dB/A (+2 dB/A before each race, +3 dB/A after the race). Tested using the 2 metre max method. A further review will be made at the end of 2020.

### Sidecars

Maximum sound limit for 2 stroke engines at 112 dB/A (+2 dB/A before the race, +3 dB/A after the race). For 4 stroke engines at 115 dB/A (+2 dB/A before the race, +3 dB/A after the race) tested using the 2 Meter Max method. A further review to be made at the end of 2020.

### Quads

Maximum sound limit 112 dB/A (+2 dB/A type 1 & 2 meters before each race) (+3 dB/A type 1 & 2 meters after each race) tested using the 2 Metre Max method. A further review to be made at the end of 2020.

### Procedure

All machines shall be sound tested using the 2 Metre Max method, the exceptions being Twin Shock and Evo Classes, the Static Test method will prevail with a test limit.

96 dBA for 2 strokes and 94 dBA for 4 strokes, using fixed RPM according to the list below, with the exception of the 500cc class.

Up to 85cc	8,000rpm
Over 85cc up to 125cc	7,000rpm
Over 125cc up to 145cc	6,500rpm
Over 145cc up to 250cc	5,000rpm
Over 250cc up to 500cc	4,500rpm
Over 500cc	4,000rpm

There is no 2 stroke/4 stroke rev differential below 500cc. Due to the influence of temperatures on sound tests, all figures are correct at 20°C. For tests taken at temperatures below 10°C there

will be a + 1 dBA tolerance. For tests below 0°C, a + 2 dBA tolerance.

There will be a + 2 dBA tolerance allowed for post race sound tests.

#### **Machines Post 2011**

The FIM 2 Metre Max Test Method will be enforced as previously detailed.

The maximum sound limit accepted: 115 dBA – + 1 dBA post race.

A sound level of 81 dBA at 100 metres during racing should be attained.

8. The Clerk of the Course may disqualify or penalise any rider of a machine which exceeds the maximum permitted sound level, or which in his opinion is deemed to be excessively noisy.
9. Random or spot checks may be made by ACU Sound Control Officials of the sound level of any machine taking part in any ACU meeting in addition to any routine checks at technical control.

## **SECTION 8 SAFETY**

### **8.1 MEDICAL SERVICES**

At all Motocross events, including official practice, qualified first aid personnel must be in attendance with full first aid equipment. Organisers must ensure sufficient medical services for the type of event remain in place until the event has completely finished.

For National and International Events a Medical Officer or Paramedic must be in attendance.

For all other status events A Medical Officer (MO) or a Paramedic (PM) or an IHCD Emergency Technician (EMT) or the Voluntary Aid Society (VAS) equivalent must be in attendance during official practice and racing.

The minimum requirement for the start of every event is two ambulances.

If one of the two ambulances has to leave the circuit then the minimum requirement for the event to continue is one ambulance and one Medical Officer (MO) or Paramedic (PM) or IHCD Emergency Technician (EMT) or the Voluntary Aid Society (VAS) equivalent, plus enough qualified first aid personnel to cover the course layout size and type of event subject to medical requirements shown below and/or specified on the TTC.

For clubs running events at Centre Restricted level and below and where there are less than 119 rider entries the minimum medical requirements are One ambulance – On the condition the ambulance is available at all times. Should the ambulance be required to support the treatment of, or transport an injured rider the meeting must stop until such time that the ambulance is available again. The ambulance should be accompanied by either a Medical officer (MO) a Paramedic (PM) or IHCD Emergency Technician or the VAS equivalent. Plus enough qualified first aid personnel to cover the course layout, size and type of event subject to medical requirements as shown in this Handbook.

It is recommended to all event organisers that any Medical Service/Personnel appointed should supply ambulances that are CQC-registered.

1. If only one ambulance is listed as the minimum requirement at an event then organisers are reminded that if it has to leave the event then all practicing and racing must stop until its return or replacement. It is incumbent therefore on organisers of events to remember their commitment and duty of care to competitors in ensuring that sufficient medical services for the type of event, dictated by a risk assessment of the expected number of injuries, are in place prior to the start of practising and racing and remain in place until the event has completely finished.
2. Auxiliary vehicles, such as 4x4 with a stretcher, cannot replace an Ambulance but such vehicles might, at certain event sites, be used in addition to and as the final form of transportation to the Ambulance for the event.

**Note** A 4x4 vehicle can be an ambulance if registered with the DVLA as an ambulance.

3. If there is a requirement for first aid personnel to be present then they can be the two crew members of an Ambulance, assuming that one is present as a minimum requirement, but they must be available for all the practices and races. Such first aid personnel are an additional requirement to any doctors or paramedics required to be present at the meeting.

4. If there is a requirement for full first aid equipment, including a stretcher, then this can be the same equipment as that defined in the minimum equipment requirements for an Ambulance.
5. If the minimal medical cover required is for only one Doctor or only one Paramedic to be present then, if the only one available has to leave, for whatever reason, the practices or races must stop until their return or replacement.
6. If a Doctor is required at an event then they must be on site. It is not sufficient to have the name and address of a distant doctor, who would or might be available if required.
7. The nearest hospital, with an Accident & Emergency Department, must be notified in writing of the time, date and place of the meeting.
8. If a Doctor is involved in the treatment of competitors or spectators at an event, they should not normally be involved with drug or alcohol testing of competitors.
9. If a medical centre is available at a circuit or the site of an event then it should be fully operational and independently staffed. If deemed acceptable, an Ambulance or similar unit may act as a medical centre but if so, it must be additional to the minimum Ambulance requirements.
10. If no Medical officer or Paramedic is required at an event then at least one of the two Ambulance crew must be qualified as an IHCD Emergency Technician or the VAS equivalent, rather than just a first aid person.
11. If a competitor is involved in an incident involving potential injury, but is not, at the time, taken to Hospital for further treatment, then a relative, or a member of their crew, should be given a copy of the medical assessment or Ambulance report form completed by the event medical personnel following the incident.
12. **Concussion/suspected concussion**

If a competitor is involved in an incident which results in him being diagnosed by the Medical Officer/Paramedic as suffering from concussion or suspected concussion, the rider is not permitted to participate any further in that event.

Organisers are to notify ACU Head Office as soon as possible of any concussion/suspected concussion injuries and then will subsequently:

- a) Place the rider on the ACU Stop List
- b) Inform Organisers of forthcoming events that the Rider has suffered a concussion/suspected concussion injury and is therefore placed on the ACU Stop List
- c) Inform the Rider that he needs to see a Doctor and obtain a letter/doctor's certificate which confirms he is fit to resume competitive racing/participate in a practice/test session.

The recovery time for anyone diagnosed with concussion/suspected concussion is as follows:

- a) Over 20 years: Excluded immediately and suspended for a period of nine days.
- b) 16–19 years: Excluded immediately and suspended for a period of twelve days.
- c) 15 and under: Excluded immediately and suspended for a period of twenty three days.

The rider is not permitted to ride during the obligatory suspended periods outlined above and then only once he is in possession of a doctor's certificate/letter after the suspended period has expired.

Exceptionally for the Maxxis British Motocross Championships only, a rider may be signed off to ride by the CMO of the event after observing the obligatory suspended period outlined above.

If a competitor has been injured on a Saturday and is suffering from concussion/suspected concussion, and the Organiser is aware that the rider was intending to ride or is scheduled to ride somewhere else the next day, the Organiser will inform the Organiser of the event being held the next day so they are aware of the rider's injuries and as such he is prevented from participating in that event.

## **8.2 CLOTHING**

1. All competitors must wear a helmet. For information regarding helmets please refer to the helmet section within this Handbook.
2. Competitors are advised not to wear hand, face or body jewellery/piercings which could prove hazardous in the event of an accident.
3. The mouth should be kept clear of anything likely to cause blockage of the airway in the event of an incident, e.g. chewing gum. This includes removing false dentures.
4. It is not advised that bulky hard objects such as tools etc. are carried in pockets or on the person.
5. Goggles or visor of a non-splinterable type must be worn at the commencement of each race. Spectacles, if worn, must be non-splinterable.
6. The use of "Tear Off" lenses on goggles is at the discretion of the event organisers. It must be stipulated in the event Supplementary Regulations if they are allowed or not for each individual event.
7. The carrying of on board cameras on helmets is only permitted with prior approval of the Chief Technical Officer or Clerk of the course. The Camera used must automatically be released from its fixing in the event of a crash. The fixings should be of the flat "pad type" and not have any uneven or high elements to it.
8. It is compulsory that riders/passengers wear, as a minimum, back and chest protectors, soft shell body armour is acceptable, incorporated within the suit or worn separately. It is advised that all riders and passengers should wear a body belt/kidney protector.
9. It is the responsibility of the rider's parent/guardian to ensure that all protective clothing is correctly fitting for youth competitors.

### **8.2.1 MOTOCROSS, SUPERCROSS AND BEACHCROSS**

In all races and official practice complete protective clothing produced for motocross racing, knee length boots and gloves shall be worn by each rider and passenger. It is advised that motocross jerseys should provide protection against abrasion to the body and arms and that motocross jeans are padded at the hips and knees.

### **8.2.2 MINIBIKE**

In all races and official practice complete protective clothing shall be worn by each rider. It is advised that Ankle boots should reach above the ankle ball. Ankle braces laced up properly and fit closely could be worn under the boot to increase stability. Jerseys should provide protection against abrasion to the body and arms. If short sleeved jerseys are worn then elbow pads must be worn to protect exposed skin. Trousers/shorts must provide protection to the knee, shin and hips. If Motocross style shorts are worn then they must cover the knee and must be used in conjunction with a knee, shin pad combination.

## **8.3 TRACK SAFETY**

See ACU Requirements for Safety Precautions at all Motocross Events held under an ACU Permit 2020.

## **8.4 FIRE EXTINGUISHERS**

All competitors must have a 2kg (minimum) dry powder fire extinguisher available for immediate use. If a 'closed vehicle' is being used the extinguisher must be fitted adjacent to, or on the inside of the working door. In the case of a shared vehicle the other competitors extinguisher(s) should also be visible, or, the fitted extinguisher(s) must be of a proportionately larger capacity. All extinguishers must have a current certificate attached.



### 8.5 RIDING IN THE PADDOCK

Riding of machines in the paddock is strictly prohibited and warning signs should be erected. Machines should be pushed with the engine dead. Riding of machines at a slow pace can be permitted if designated lanes are provided. Machines must be pushed upon exiting from any point on these lanes. Riding to and from the Paddock – In exceptional circumstances or if permitted by the Clerk of the Course riders must not exceed first gear idle when travelling to and from the paddock area and must always wear a helmet.

### 8.6 TRACK ACCESS

Strictly no personnel, other than signed on officials, are permitted on the track while machinery is operating.

### 8.7 FLAG SIGNALS

The following flag signals will be used:

<b>National Flag</b>	This flag can be used for starting a race.
<b>Red</b>	All Riders must stop. Riders must not pass any red flag unless authorised or directed to do so and then proceed at a slow pace.
<b>Black with the riders number clearly shown on a board</b>	That rider to stop racing immediately and leave the track.
<b>Yellow Motionless</b>	Danger, take care. ride with caution.
<b>Yellow Waved</b> Marshals are only advised to wave their flags when riders are stopped on the course in a dangerous position or being attended to by officials or medical staff	Great Danger, prepare to stop, no overtaking. A significant reduction in speed must be seen, therefore jumps should not be attempted.
<b>Green</b>	Riders under starter's orders.
<b>Blue</b>	Warning you are about to be lapped.
<b>Yellow with Black Cross</b>	Last Lap./(either or) a two lap and then one lap board, clearly marked.
<b>Chequered</b>	Finish.
<b>White with Red Diagonal Cross Raised &amp; Motionless</b>	Medical attention required at that post.
<b>White with Red Diagonal Cross Waved For National Adult and Youth events only.</b>	Medical Crew & Officials in attendance on live race track. Proceed with extreme caution, riders must significantly reduce speed and roll each jump individually with no overtaking until past the area of concern

N.B. 'Waved' shall mean a flag should be moved up and down through an arc of 45 degrees and not indiscriminately.

Only authorised officials are permitted to use these flags. Any rider who is judged to have taken unfair advantage whilst a yellow flag is displayed and waved, or ignored any other flag signal, may be disqualified. All of the above flags should measure not less than 750mm × 600mm.

## SECTION 9 RACE MANAGEMENT

### 9.1 ENTRIES

A motorcycle sport entry form must be completed and signed by each entrant, rider or

passenger. All riders, passengers and appointed persons responsible for minors must register arrival at an event by signing on at the event race office or designated area.

## **9.2 PRACTICE**

1. Time must be put aside for the practice sessions and these must be defined in the Supplementary Regulations for the meeting.
2. Riders will commence practice under the instructions of the start officials and must join the circuit from the designated area.
3. The duration of practice will commence from the time when the first rider joins the circuit.
4. The waving of the chequered flag will indicate the end of practice.
5. For any race there must be a minimum period for practice on the actual course, the details of which must be stated in the Supplementary Regulations.

## **9.3 START POSITIONS**

1. Start positions will be established according to the provisions of the Supplementary Regulations.
2. Where the organisers decide the grid positions will be by ballot this must be conducted by the competitors at the meeting.

## **9.4 ELECTRONIC TIMEKEEPING**

1. Only licensed ACU, MSA or equivalent Timekeepers can time a qualification practice where qualification to a final, a series of races, or start line positions is the determined outcome. Organisers must inform competitors if times are official or unofficial. The Chief Timekeeper should be stated in Supplementary Regulations, official programmes and on all results sheets provided.
2. Electronic lap scoring equipment does not require official timekeepers to operate a system but it is advised that manual lap scoring is carried out to support an electronic system.
3. If timed practice is used and identical times are recorded by more than 1 rider in the official qualifying practice session for the race the rider first setting such a time will receive the better starting position.
4. Transponders, if used, should be fitted to the machine as per the timekeepers or manufacturers instructions, it is the rider's responsibility to ensure that the correct transponder is securely fitted, it is the rider's responsibility if a transponder is lost from the machine during an event.

## **9.5 RACES**

1. The race category and durations should be stipulated in the Supplementary Regulations.
2. In the event of a race being cancelled due to insufficient entries, the promoters reserve the right to offer the race time and prizes for a race of similar length for machines of another class or suitable category.

## **9.6 METHOD OF STARTING**

The method of starting shall be stated in the Supplementary Regulations.

## **9.7 STARTER'S ORDERS**

1. Riders are deemed to be under starter's orders when the first rider is called to the start line, signified by the raising of a green flag.
2. Riders in the 65cc or 85cc SW class will be allowed assistance from the start line officials if necessary, by raising their hand, to activate their launch control devices. This procedure is not deemed compulsory.
3. Any rider causing a start to be unnecessarily delayed in the opinion of the starter and/or the Clerk of the Course may be disqualified.

4. No persons will be allowed in the start area once riders have come under orders at the start line, except riders, passengers and authorised officials.
5. Once the riders are under starter's orders, the start procedure should not commence until the circuit is clear, signified by the lowering of the green flag.
6. If a 15 and 5 second board is used the following procedure will be followed:
  - The 15 second board will be displayed for a full 15 seconds.
  - The 5 second board will be displayed for a full 5 seconds.
  - The gate will drop between 5 and 10 seconds after the "5 seconds" sign is shown.

### 9.8 FALSE STARTS

All false starts shall be indicated by the waving of a red flag, all riders will have to go back to the starting area and await announcements regarding the restart.

### 9.9 STOPPING A RACE

1. If a race is stopped before the leader has completed three laps, the race may be re-run at the discretion of the Clerk of the Course.
2. If a race is stopped under 50% of the race distance excluding any additional laps and over 3 laps completed by the leader the result will be taken at the end of the penultimate lap during which the signal to stop the race was given, a minimum of three laps must be shown on the completed race result. The race may be re-run at the discretion of the Clerk of the Course.
3. If a race is stopped after 50% of the race time has elapsed, excluding any additional laps, the result will be declared on the last completed lap.
4. In the event of a race being re-run the Clerk of the Course may disqualify any rider or riders who is/are the prime cause of the race initially being stopped.
5. If a race has to be stopped after the leader has completed 50% of the race distance, excluding any additional laps, rounded down to the nearest number of laps, it will be considered to have finished.
6. a) The order of classification shall be based upon the order of last crossing the finishing line prior to the showing of the red flag and only competitors who are racing at the showing of the red flag will be classified.  
b) If a race has to be stopped after the leader(s) has taken the chequered flag they will be classified as having finished the race. The order of classification for those riders who have not taken the chequered flag shall be based upon the order of last crossing the finish control line prior to the showing of the red flag and only competitors who are racing at the showing of the red flag will be classified.  
c) The Clerk of the Course may disqualify/penalize a rider from the results who has deemed to be the cause of the red flag incident.
7. For Adult National races to be classified as a finisher, riders must have completed 50% of the total laps completed by the race leader, or as per the Supplementary Regulations.
8. For Youth National races to be classified as a finisher, riders must have completed 50% of the total laps completed by the race leader, or as per the Supplementary Regulations.
9. Only the Clerk of the Course or his assigned assistants can stop a race, all courses must have sufficient assistants to ensure that when a race is stopped this decision is communicated to all of the riders as quickly as possible. A TCC can state how many assistants are required for a course and if radio communication is required.
10. For British Championship races please refer to the Supplementary Regulations.

### 9.10 FINISH OF RACE

1. The chequered flag will be displayed as the winner crosses the finish control line and will be kept flying thereafter until the last riders finish the lap.
2. No rider will be allowed to start a fresh lap after the chequered flag has been displayed.

3. Riders crossing the finish control line will be flagged off, their position being determined by the number of laps each has completed, those riders who complete a similar number of laps having their positions determined by the order in which they cross the finish control line or appear on the final results. A rider does not have to cross the finish control line to be classed as a finisher within the time limit as laid down in the Supplementary Regulations.
4. If the chequered flag or last lap flag is mistakenly displayed later than the official time/distance, the finishing order shall be determined by the running order at the official time/distance. Under any circumstances, such as mistaken display of the chequered flag or last lap flag before the official time/distance, the finishing order shall be determined by the running order at the time the chequered flag is displayed.

### 9.11 RACE RESULTS

1. If the results are to be decided on points, the points allocation must be clearly defined in the Supplementary Regulations along with the method of deciding ties.
2. When a race has been completed the results will be based on the order in which a rider crossed the finish control line and the number of laps completed.
3. Should a tie occur on an overall result the highest position in the final leg will determine the final order.
4. It is the rider's responsibility to check the official results board/sheets for his finishing position and/or any penalties issued.
5. Series of Championship rounds – If the Championship Regulations allow for race results to be dropped then a rider who receives disqualifications during the year will not be allowed to consider/count them as one of his worst individual results etc. If a rider receives penalties during the year this could be considered/count as one of his worst individual results.

### 9.12 CHANGE OF MACHINE

A change of machine may be permitted provided the machine has been through Technical Control procedure. The same machine must be used throughout any one race.

### 9.13 CHANGE OF SIDECAR PASSENGER

1. The only reason to change a passenger is injury and only one change per meeting will be allowed.
2. The passenger must sign on, have the correct licence, and complete a sighting lap.
3. Application for a change must be in writing to the Clerk of the Course at least 30 minutes before the start of the race.
4. The final decision will be left with the Clerk of the Course.

### 9.14 OUTSIDE ASSISTANCE

1. If during a race a rider and/or passenger receives outside assistance other than that provided by the Organisers for the removal of himself or his machine from the course in the interests of safety, that rider may be disqualified.
2. Riders receiving signals from persons associated with them in prohibited areas may be disqualified.
3. The use of two way radios with a rider/passenger is prohibited.
4. Only riders who are competing in the race on the circuit are insured. Signed on riders who are not competing in the session on circuit are treated as spectators.

### 9.15 FOUL, UNFAIR OR DANGEROUS RIDING

The Clerk of the Course may penalise any rider who, in his opinion, is guilty of unfair, foul or dangerous riding.

### 9.16 COURSE CONDUCT

1. If, for any reason, a rider leaves the course, they must rejoin it as closely as possible at the point where they left the course without any outside assistance. They must not gain any advantage. If any advantage is obtained they may be penalised or disqualified from the results.
2. If any rider leaves the track boundaries they shall not be allowed to re-join the race.
3. Riders must at all times adhere to the direction of racing. Exception may be given when this cannot be achieved due to the nature of the terrain. The decision of any such exception will in the first instance be judged by the Clerk of The Course or Race Direction.

### 9.17 AWARDS

1. Awards of any description must be described in the Supplementary Regulations; the method of distribution must be announced before the completion of the event.
2. Awards for youth riders in youth events: Cash, gift vouchers, and goods are only permitted in the group A1 Open class and group G (Quad) 250cc Open Youth classes.

## SECTION 10 GENERAL

### 10.1 INSTRUCTIONS TO RIDERS

Any Supplementary Regulations or instructions to riders subsequently issued, shall have the same force as these Standing Regulations but must in no way contradict these Standing Regulations.

### 10.2 CONDUCT

Riders, parents or associates failing to obey instructions given by officials of the meeting or deemed to have unjustifiably or maliciously jeopardised the efficient running of the meeting by not adhering to the Regulations, Supplementary Regulations or the protest procedure, may be disqualified from the meeting.

See also the National Sporting Code, Offences and Penalties.

### 10.3 PARENTAL RESPONSIBILITY

It is a parent's or guardian's responsibility to ensure that children stay within the confines of the event site and obey all instructions issued by the organiser.

### 10.4 DECLARATION

It is a condition of acceptance of entry that the promoters shall not be responsible for any damage to a motorcycle or its accessories whether by fire, accident or other causes, nor for the theft of a motorcycle or its accessories before, during and after the meeting.

### 10.5 COMPLIANCE WITH REGULATIONS

Every rider by entering or being entered or nominated, thereby acknowledges that he is bound by the National Sporting Code of the ACU and these Standing Regulations together with any Supplementary Regulations or Conditions and Final Instructions to be hereafter issued, to all of which he undertakes to submit and, moreover, renounces any right to have recourse to any arbitration or tribunal not provided for. All safety precautions for ACU Motocross events are available in a separate publication from the ACU.

### 10.6 DOGS AT OFF ROAD MOTORCYCLE EVENTS

Whilst dogs are not discouraged from attending Off Road Motorcycle Sport events, they are to be kept on a lead and under control at all times. Owners are responsible for ensuring their dog is kept under control and are responsible for clearing up any fouling that may occur.

## SECTION 11 BEACHCROSS

### 11.1 SPECIFICATION OF MOTORCYCLE

All machines must comply with the appropriate specification applicable to the type, that is to say, Trial, Trail, Enduro, Motocross or ATVs. Paddle or scoop tyres are strictly forbidden.

### 11.2 LPG FUEL/DIESEL

Vehicles using LPG fuel must comply with the LPGA Code of practice 11. for auto gas installations June 2001, and will be subject to refuelling regulations, including a minimum 11kg fire extinguisher. Diesel fuel must be 'roadside pump' available.

### 11.3 CIRCUIT

Hazards should become progressively harder around the circuit so that large numbers of riders are not stopped at the first hazard on the first lap. A number of flag marshals must be placed at each obstacle subject to the pre race risk assessment.

### 11.4 STARTER'S ORDERS

A rider shall be deemed to be under starter's orders when he collects his machine from the parc ferme/waiting zone.

### 11.5 FINISH OF A RACE

The chequered flag will be displayed as the winner crosses the finish control line and will be kept flying thereafter until the last rider finishes that lap. No rider will be allowed to start a fresh lap after the chequered flag has been displayed. Thereafter riders crossing the line will be flagged off, their position being determined by the number of laps each has completed, those riders who complete a similar number of laps having their positions determined by the order in which they finished within the time limit laid down in the Supplementary Regulations will be declared finishers. The organisers reserve the right to declare in the Supplementary Regulations the distance required to be declared a finisher.

### 11.6 DURATION OF A RACE

As specified in the Supplementary Regulations.

### 11.7 INTERRUPTION OF A RACE

The Clerk of the Course for reasons of safety may temporarily stop the event by the waiving of a red flag at any point on the circuit. The race will resume on the raising of the green flag by the Clerk of the Course.

### 11.8 DISQUALIFICATIONS

Any rider considered for disqualification may be allowed to complete the race and be disqualified, subject to protest and appeal procedures. If in the opinion of the Clerk of the Course the offence is undisputable the rider can be disqualified from the race immediately. The Clerk of the Course must write down the time, details of the offence and time of the disqualification to be given to the Stewards as soon as is possible.

## SECTION 12 CROSS COUNTRY QUADS STANDING REGULATIONS

### 12.1 MEETINGS

#### 12.1.1 DEFINITION

Cross Country events are controlled Group Start events which are a test of endurance and reliability. Competitors will be required to complete a number of laps within a time set by the organisers. The duration of events will be stated in the Supplementary Regulations.

### 12.1.2 PROCEDURE FOR STOPPING AN EVENT

Where it is deemed necessary to stop an event, only the Clerk of the Course or his assigned assistants can stop an event. All courses must have sufficient assistants to ensure that when a race is stopped this decision is communicated to all of the riders as quickly as possible.

## 12.2 ELIGIBILITY

### 12.2.1 ELIGIBILITY

All Adult riders must hold a current ACU or SACU licence and be a minimum age of 15 years. Any rider from another FMN MUST produce a licence issued by their FMN together with start permission and proof of personal accident Insurance.

**Day Licences.** A one event Competition Licence grants the same benefits of an annual licence for the duration of the one event and is available for up to and including National Status.

Youth rider may compete in these events but must be a minimum of 7 years of age and a maximum of 16 years and is restricted to a maximum machine capacity of 250cc.

### 12.2.2 CAPACITY & RESTRICTIONS

Subject to the Supplementary Regulations any quad machine which complies with the Motocross Specifications as per the current ACU Handbook, may be allowed.

#### Adults +15 yrs

C1: Championship	For machines up to 550cc max 2 cylinder 2 stroke or up to 800cc 4 stroke max 1 cylinder
C2: Experts	For machines up to 550cc max 2 cylinder 2 stroke or up to 800cc 4 stroke max 1 cylinder
C3: Clubman	For machines up to 550cc max 2 cylinder 2 stroke or up to 800cc 4 stroke max 1 cylinder
C4: Utility & 4x4	For machines up to 550cc max 2 cylinder 2 stroke or up to 800cc 4 stroke max 1 cylinder

#### Youth Quad

Max cc	Age	Type	Specification
50cc (Y1)	7–9 yrs	Automatic Quad	Performance Modifications are allowed up to a maximum of 50cc. Engine must not exceed 50cc at time of Manufacture.
100cc Auto (Y2)	8–13 yrs	Auto, 100cc Production Quads built by the manufacturer	Engine must not have exceeded 100cc 2 Stroke Auto/150cc 4 Stroke Auto
100cc Open (Y2)	9–13 yrs	Open Geared Class Max 100cc 2 Stroke/150cc 4 Stroke	Engine must not have exceeded 119cc 2 Stroke/179cc 4 Stroke.
150cc Open 2–150 (Y3)	11–16 yrs	Open Geared Class Max 100cc 2 Stroke Air Cooled/150cc 4 Stroke Water Cooled	Engine must not exceed 119cc 2 Stroke/179cc 4 Stroke. 150cc Open 2 Class compete in the 250cc Race Group
250cc Air Cooled (Y3)	11–16 yrs	Air Cooled Production Quads	Performance Modifications are allowed to the Engine & chassis up to a maximum of 239cc 2 Stroke/299cc 4 Stroke. Frame & Engine must be by the original Manufacturer. Engine must not exceed 239cc 2 stroke/299cc 4 Stroke
250cc Open (Y4)	14–17 yrs	Open Class (Hybrids allowed)	Engine must not 239cc 2 stroke/299cc 4 Stroke

No engine displacement reductions are allowed (sleeved down bigger engines to fit the cc criteria are not allowed)

## 12.3 CLASS VARIATIONS

### 12.3.1 VARIATIONS

The Youth class must be run as a separate session from any Adult classes at the same event and must not be combined with any Adult classes at the same event. Youth capacity/Age/ability classes must be stated in the supplementary regulations.

## 12.4 LICENCES AND REGISTRATIONS (OFFICIALS)

As per Motocross Standing Regulations.

## 12.5 SPECIFICATION OF A MOTORCYCLE

Category G (Quad) shall comply with the National Sporting Code appendix D and the following:

### 12.5.1 MOTORCYCLES

Subject to the Supplementary Regulations any Quad which complies with the Motocross Specifications as per the current ACU Handbook may be allowed.

### 12.5.2 TYRES

Tyre type is optional or as stated in the Supplementary Regulations.

## 12.6 NUMBER PLATES

All Quad machines must be fitted with a front & rear number plate of a minimum size of 150mm × 150mm with the rear mounted behind the rider on the rear grab bar, and be in line with the machine reading left to right on both sides. The mounting bracket must not be higher than 150mm. Height of the number 100mm. Width of the number 80mm. Width of stroke 25mm. Space between two numbers 15mm.

Adult Quads	Background Colour	Number Colour
C1: Championship	Red	White
C2: Experts	Green	White
C3: Clubman	Yellow	Black
C4: 4x4 Utility	White	Black
Youth Quads		
50cc (Y1)	White	Black
100cc Auto (Y2)	Blue	White
100cc Open (Y2)	Red	White
150cc Open 2-150 (Y3)	White	Black
250cc Air Cooled (Y3)	Blue	White

## 12.7 TECHNICAL CONTROL

- As per Motocross Standing Regulations.
- Helmets** – Helmets bearing the ACU gold or silver stamp, in sound condition and properly fitted must be worn by all competitors. Please refer to the section in this Handbook titled ‘Helmets’ for other important information and conditions concerning European Community Exemption.
- Jewellery** – Competitors are advised not to wear hand, face or body jewellery which could prove hazardous in the event of an accident. The mouth should be kept clear of anything likely to cause a blockage of the airway in the event of an accident, e.g. chewing gum. This includes removing false dentures.
- Noise control** – Machines must be within the noise levels currently in force for that category of machine (see respective Standing Regulations).



## **12.8 SAFETY**

### **12.8.1 MEDICAL SERVICES**

As per Motocross Standing Regulations.

### **12.8.2 CLOTHING**

As per current Motocross/Enduro Standing Regulations.

### **12.8.3 FIRE EXTINGUISHERS**

All competitors with the exemption of those travelling to an event on the machine on which they are competing, must have a 2kg (minimum) dry powder fire extinguisher available for immediate use. If a 'closed vehicle' is being used the extinguisher must be fitted adjacent to, or on the inside of the working door. In the case of a shared vehicle the other competitor's extinguisher(s) should also be visible, or, the fitted extinguisher(s) must be of a proportionately larger capacity.

## **12.9 RACE MANAGEMENT**

### **12.9.1 COURSE**

Must be 'off-road' and the minimum time should be set in the Supplementary Regulations. The organisers may split the event into 2 or more legs if desired but the minimum time for each leg must be set in the Supplementary Regulations. The ratio of competitors to course will be – 30 riders per km of course, e.g. 180 riders must have 6 km lap distance etc.

Any restrictions on the number of machines used by Team riders are to be stated in the Supplementary Regulations. All machines used are to be subject to Machine Examination.

For the Y5 Beginner production class organisers must ensure visual contact is applied at each rider at all times.

Special attention should be given to riders in this class for fatigue during the race.

The organisers must also ensure that each rider entered in this class is able to reasonably control their machine and should be identified by the wearing of a high visibility bib.

### **12.9.2 START**

The start must be set out so that riders will start in groups which will be decided by the organisers e.g. capacity classes, ability classes etc. These groups will be defined in the Supplementary Regulations.

The number of riders in each group – which must not exceed 40 – and the start interval between groups – which must be no less than 30 SECONDS – will be decided by the organiser and due regard to course layout and the approval of the permit issuing authority. The organisers must ensure that the entire entry must be able to start and leave the start area before earlier riders start subsequent laps. In all circumstances there must be a dead engine start. This may limit the size of entry. Any rider who fails to start their machine at the allotted start time for their group will be credited for that original start time regardless of the actual time that they start. Start procedure will be stated in the Supplementary Regulations.

### **12.9.3 LAP SCORING AREA**

An area must be designated which allows riders to pass through single file gates where their number will be recorded on the completion of every lap. Where there is more than one class the organiser may set alternative durations to suit the varying abilities. The organisers may stipulate that riders have to stop. The lap scoring area will be deemed as a "Blue Tape" area and marked as such.

### **12.9.4 FINISH**

After the specified time/number of laps, the riders will be diverted through the lap scoring area and then from the course.

### **12.9.5 FINISHING ORDER**

The winner overall and of any respective classes will be the riders who have achieved the closest number of laps to the duration set on the allotted time. Each riders start time will be taken as their respective groups start time, or individual start time as decided by the Organiser and their individual finish time will have been recorded.

**12.9.6 FINISH OF RACE**

1. The chequered flag will be displayed as the winner crosses the finish control line and will be kept flying thereafter until the last riders finish the lap.
2. No rider will be allowed to start a fresh lap after the chequered flag has been displayed.
3. Riders crossing the finish control line will be flagged off, their position being determined by the number of laps each has completed, those riders who complete a similar number of laps having their positions determined by the order in which they finish.
4. Only riders crossing the finish control line within the time limit laid down in the Supplementary Regulations will be declared as finishers.
5. For all Adult National races. To be classified as a finisher, riders do not have to cross the finish control line, but riders must have completed 50% of the total laps completed by the race leader, or as per the Supplementary Regulations.
6. For all Youth National races. To be classified as a finisher, riders do not have to cross the finish control line but riders must have completed 50% of the total laps completed by the race leader, or as per the Supplementary Regulations.

**12.9.7 TIES**

Will be decided on the laps completed and the individual times of each rider.

**12.9.8 CHECKS**

The start/finish will be the only time check. There should be adequate marshals/route checks on the course to prevent course cutting.

**12.9.9 MARSHALS**

Organisers should place marshals at strategic points around the course to monitor safety and ensure control of event. Additional clearly identified Travelling Marshals can also be used to achieve this.

**12.9.10 PUBLIC SPECTATOR AREAS**

The Supplementary Regulations must announce the provision of clearly identified specific areas which must be used by all non competitors other than riders or officials. Warning notices must be placed at appropriate points around the course to prevent public access.

**12.9.11 RESTRICTED SPEED (BLUE TAPE) AREAS**

These areas MUST be established on the approach to the Time Control/Lap Scoring area and any Re-fuelling and works areas. Within 'BLUE TAPE' areas the rider must not exceed walking pace, under Penalty of exclusion. The Incident Officer/Clerk of the Course may also establish 'BLUE TAPE' areas at other parts of the course if required.

**12.9.12 RE-FUELLING**

A suitable and restricted area must be marked out adjacent to the course as a pit area. Access to this area must be restricted to marshals, riders and authorised helpers. The area should be manned by marshals and access only allowed to officials, competitors and authorised helpers. The Organiser MUST establish a fire point, clearly indicated and with the appropriate fire extinguishers present. Each rider shall ensure that his re-fuelling crew, have a fire extinguisher at the re-fuelling point as described in Regulation 3.13. 'No Smoking' signs should be displayed.

**THE ENGINE MUST BE STOPPED AND THE RIDER OFF THE MACHINE DURING REFUELLING. NO SMOKING ALLOWED. REFUELLING MAY ONLY BE CARRIED OUT IN THE DESIGNATED AREA.**

**12.9.13 OUTSIDE ASSISTANCE**

1. If during a race a rider and/or passenger receives outside assistance other than that provided by the Organisers for the removal of himself or his machine from the course in the interests of safety, that rider may be disqualified.
2. Riders receiving signals from persons associated with them in prohibited areas may be disqualified.
3. The use of two way radios with a rider/passenger is prohibited.

Assistance will only be allowed in the pit area, except when provided on the course by the organisers.

**12.10 GENERAL****12.10.1 ENTRIES**

A Motorcycle Sport Events Entry Form must be completed in every detail, and signed by each entrant, rider. (N.B. a requirement of signing and entry application form is that each signatory understands the National Sporting Code of the ACU, Standing Regulations, such Supplementary Regulations as have been issued for the event and such Final Instructions subsequently issued, and agrees to be bound by them).

Limitations of Entries. If entries are to be limited, the maximum number and method of limitation (i.e. in order of receipt, by ballot etc.) Will be stated in the Supplementary Regulations.

Child Protection. The point of contact for Child Protection issues will be the Secretary of the Meeting unless otherwise stated in the Supplementary Regulations.

**12.10.2 ACCEPTANCE OR REFUSAL OF ENTRY**

The Organiser must notify all riders of the position regarding their entry prior to the event. The method for notification will be stated in the Supplementary Regulations for the event.

**12.10.3 PUBLIC WARNING**

Notices must be displayed in accordance with the Safety Precautions section of the current ACU Handbook.

**12.10.4 DOGS**

Whilst dogs are not discouraged from attending Off Road Motorcycle Sport events, they are to be kept on a lead and under control at all times. Owners are responsible for ensuring their dog is kept under control and are responsible for clearing up any fouling that may occur.

**12.10.5 COMPLIANCE WITH REGULATIONS**

Every rider by entering or being entered or nominated, thereby acknowledges that he is bound by the National Sporting Code of the ACU and these Standing Regulations together with any Supplementary Regulations and Final Instructions to be hereafter issued, to all of which he undertakes to submit and moreover renounces any rights to have recourse to any arbitrations or tribunal not provided for.

**SECTION 13 GRADING****13.1 ACU MOTOCROSS RIDERS EXPERT GRADING SCHEME (ADULT)**

Expert status will be given to riders who appear on the Expert list compiled by the ACU Office. You can qualify for Expert Listing by the following means:

- Point scorer in an adult National Motocross Championship.
- Registered Rider in the ACU British MX Championship – MX1/MX2.
- Top 10 point scorer in the British Youth Championship – 125/250f class (Open).
- Selected by Centre Recorders based on Regional or Club Championships.
- Upgraded by the Motocross Committee.

Riders may be removed from the list after two years if they have not scored any regional or national Championship points.

**UPGRADING TO INTERNATIONAL**

**Sidecar Competitors** – There will be no grading for sidecar competitors.

**Quad Riders** – There will be no grading for quad riders.

The Central Recorder for the Motocross Grading Scheme is:

Mrs S Goggin, ACU House, Wood Street, Rugby, Warwickshire, CV21 2YX. Tel: 01788 566404.

# SECTION 14 MOTOCROSS MOTORCYCLE

