

# **Track Racing**

## Standing Regulations

<b>SECTION 1</b> GENERAL	<b>224</b>
<b>SECTION 2</b> PROCEDURES	<b>226</b>
<b>SECTION 3</b> RIDERS	<b>230</b>
<b>SECTION 4</b> TECHNICAL	<b>232</b>
<b>SECTION 5</b> SAND/BEACH RACING	<b>240</b>
<b>SECTION 6</b> SHORT TRACK	<b>241</b>
<b>SECTION 7</b> SHORT TRACK TECHNICAL REGULATIONS	<b>241</b>
<b>SECTION 8</b> YOUTH COMPETITOR REGULATIONS	<b>241</b>
<b>SECTION 9</b> GRASS TRACK EVENTS HELD ON SPEEDWAY CIRCUITS	<b>244</b>
<b>SECTION 10</b> TRACK RACING OFFICIALS	<b>244</b>

The Sporting Code and the Standing Regulations of the ACU together with the Supplementary Regulations will apply to all Grass Track Races.

## SECTION 1 GENERAL

### 1.1 COMPLIANCE WITH REGULATIONS

Every rider (and parent/guardian for youth) entering or being entered acknowledges that he/she is bound by the ACU Sporting Code, these Track Racing Regulations, together with any Supplementary Regulations and Final Instructions thereafter issued to all of which they undertake to submit and moreover, renounce the right to have recourse to any arbitration or tribunal not provided for in the rules.

### 1.2 ELIGIBILITY

For National Competitions, Entrants, Drivers and Passengers must hold a current Competition Licence for International or National Events issued by the ACU, or the Scottish ACU. Organisers may allow licence holders from FMNs within FIM Europe to participate. Start permission from the relevant FMN must be submitted to the organiser and any additional third party insurance must be obtained. For all competitions of below National Status, a current Competition Licence of the appropriate grade is required. Details of eligibility will be found in the Supplementary Regulations of the event.

Applicants for Youth Licences please refer to the Youth Licence Regulations within this Handbook. The minimum age for an adult competitor is 16 years, but applications will be considered by the Track Racing Committee (TRC) for 15 year olds to ride in the 250cc and 350cc classes. The minimum age for 1000cc sidecar Drivers and passengers is 17 years. Minimum ages for 500cc Right Hand Sidecar class is 15 for drivers and passengers. Any competitor over 70 years of age must have a medical examination.

### 1.3 NON-STARTERS/RESERVES/SUBSTITUTES

The place of any non-starter shall be taken by a RESERVE driver whose entry has been accepted, and in the order of priority as listed in the Official Programme of the Competition. A SUBSTITUTE driver may be nominated only by the ENTRANT being the holder of an Entrant's International or National Competition Licence. Where a rider is his own Entrant, no substitution will be permitted (see Sporting Code). A change of passenger during a meeting is permitted if authorised by the Clerk of the Course.

### 1.4 ALTERATIONS TO PROGRAMME

In the event of a race being cancelled due to insufficient entries, the organisers reserve the right to offer the race time and prizes for a race of similar length, for machines of another class or category.

### 1.5 ABANDONMENT

The organisers reserve the right, subject to the approval of the Stewards of the Meeting, to cancel, postpone or abandon any event, or the competition itself, if circumstances should arise which in their opinion, renders such action necessary.

### 1.6 BRITISH INDIVIDUAL GRASS TRACK CHAMPIONSHIPS

It is a condition of the issue of a National Competition Licence that the competitors will not be granted authority to compete at home or overseas at any event which clashes with the Qualifying rounds or the Final of an Individual Championship for which they have qualified or may be nominated for.

Competitors should also note the requirements for International Selection through the appropriate Individual Championship. However, following a written request to the TRC, permission may be

given for a rider to compete at a FIM EUROPE or FIM Championship event which conflicts with the date of an Individual Championship event within the UK.

### 1.7 ADULT GRASS TRACK RECORDINGS

Events at which points may be allocated are Restricted, Open, National, European Open and International.

Points are allocated on the results of the first final for each class at each event. Should the race be run on, for example, a three leg basis, the points should then be given on the overall results. If in doubt, a good guide is to use the published result and/or result on which the awards are presented. Points will only be allocated for one event in each capacity class at each meeting i.e. one 250cc Final, one 350cc Final, one 500cc Final and one Final of each Sidecar classes. Riders will be allocated points in each of the capacity classes in which they compete. Joint 250cc & 350cc races can be awarded points corresponding to their results within their class. Unlimited capacity classes do not carry any grading points. Points allocation for classes as follows:

#### All Track Racing Events

1st	6 points
2nd	5 points
3rd	4 points
4th	3 points
5th	2 points
6th	1 point

For Track Racing events where 8 or less Solo competitors and six or less Sidecar competitors are entered the points will be allocated:

1st	3 points
2nd	2 points
3rd	1 point

### 1.8 GRASS TRACK RECORDERS

**National Co-ordinator:** Mrs. T. Cossar, ACU House, Wood Street, Rugby, Warwickshire CV21 2YX.  
Tel: 01788 566402.

**Cornwall Centre:** Mr M Courtney, Carbis Wharf, Roche, St Austell, Cornwall PL26 8LA.  
Tel: 07810885174 mark.courtney26@gmail.com.

**Eastern Centre:** Mr. J. Sayer, Hylands, Dunmow Road, Thaxted, Essex CM6 2NX. Tel: 01371 870123.

**East Midland Centre:** Mr R Smith, 18 Alma Street, Melbourne, Derby DE73 1GA Tel: 07877 751278.  
rob@smith8615.freerve.co.uk.

**East Yorks Centre:** Mr. D. A. Brown, 4 Brockfield Road, Huntington, York YO3 9DZ.  
Tel: 01904 622274.

**Midland Centre:** Mrs. D. Edwards, Oak Lodge, Buckwyns Chase, Billericay, Essex CM12 0TN.  
Tel: 01277 632249.

**Mid Wales Centre:** Mr. M. Kilvert, Windy Way, Nantoer, Newtown, Powys SY16 1HH.

**North Western Centre:** Mr A Brown, 20 Albany Drive, Walton-le-Dale, Preston. PR5 4TY.  
Tel: 01772 497747. 07863 557183. adrian@deklanbrown.com.

**South Eastern Centre:** Mr. M. Godden, 6 Green Lane Cottages, Green Lane, Tonbridge, Kent TN12 9RE. Tel: 01892 730922.

**Southern Centre:** Mrs. D. J. Read, 12 Heights Road, Upton, Poole, Dorset BH16 5QL.  
Tel: 01202 778136.

**South Midland Centre:** Mr D. Porter, 22 Belper Road, Luton, Beds LU4 8RG.  
Tel: 07710 435127/01582 651189.

**South Western Centre:** Mr. C. Pattison, 6 Churchfields, Wincanton, Somerset BA9 9AJ.  
Tel: 01963 33001.

**Wessex Centre:** Mr. M. Melksham, 91 Headford Avenue, Bristol, Somerset BS5 8PE.

Tel: 01179 095479.

**Western Centre:** Mr. T. Vivian The Cottages, Blakes Lane, Guarlford, Malvern, Worcs. WR13 6NZ

Tel: 01684 311582.

**Yorkshire Centre:** Mr A Brown, 20 Albany Drive, Walton-le-Dale, Preston. PR5 4TY.

Tel: 01772 497747. 07863 557183. adrian@deklanbrown.com.

### 1.9 CLERK OF THE COURSE

A list of current National ACU Clerks of the Course is available from the ACU Head Office.

## SECTION 2 PROCEDURES

### 2.1 DIRECTION OF RACING

Solos A, 500cc Sidecar B1(c), 1000cc B1 (b), will race in an anti-clockwise direction. 1000cc Sidecar.

B1 (a) will race in a clockwise direction.

### 2.2 RUNNING OF ENGINES

The running of engines is prohibited except during official practising and actual racing, and for a period not exceeding five minutes prior to the start of each race. A breach of this regulation will involve disqualification from the meeting of the driver of the motorcycle concerned.

### 2.3 CONTROL OF EXHAUST SOUND LEVEL

The Clerk of the Course may exclude any machine which exceeds the maximum permitted sound level, or which in his opinion is deemed to be excessively noisy. The sound level will be controlled either by the fitment of an FIM homologated silencer or, in the absence of homologated silencers according to the FIM 2 Metre Max Method where the sound levels will not exceed 81 dB(A) when measured at a distance of 100 metres. For precise method of testing, please refer to the Sound Control Regulations within this Handbook. Random or spot checks may be made by ACU Sound Control Officials of the sound level of any machine not fitted with an FIM homologated silencer taking part in any ACU meeting in addition to any routine checks at Technical Control. The engine piston stroke in millimetres must be permanently and prominently displayed on the crankcase for use in sound control calculations. Exhaust Heatshields are recommended but not mandatory with the exception of the 500cc sidecar class.

### 2.4 ENGINES MEASUREMENT

Where it becomes necessary for the ACU or an organiser to verify any fact relating to an engine size, it shall be carried out at the cost of the rider. Where an engine is measured, as the result of a protest, the protest must be submitted with the appropriate fee plus a deposit of £50.00 for a single cylinder engine and £250.00 for a multi-cylinder engine which can only be returned if the protest is upheld. If the protest is unsuccessful then the deposit will be awarded to the person against whom the protest has been made and the protest fee will be sent to the ACU Benevolent Fund. The Clerk of the Course shall judge as guilty anyone who refuses to present an engine for measurement. The rider will be excluded from the results of the event and will be fined. If engines are presented for measurement, but this cannot be carried out at the event, the engines must be sealed for later measurement. If seals are damaged or removed the rider will be excluded from the results and fined. A sealed engine must be measured before the next round of that championship for which it has qualified, or within 28 days, whichever is the sooner.

### 2.5 ENVIRONMENTAL PROTECTION

a) Environmental mats must be used by all competitors to prevent the discharge of fuel, oil, cleaning fluids, degreasants, cooling and brake fluids from contaminating the ground.

- b) The power washing of motorcycles is not permitted at Grass Track events.
- c) Competitors and their teams must make use of the containers provided by the organiser for the disposal of oils and other waste material.

## 2.6 TECHNICAL CONTROL

All motorcycles and protective clothing must be presented to the Technical Official for examination before the start of any practice, or at any time during the meeting as may be required by the Clerk of the Course, to ensure that they comply with the requirements of the regulations. Spokes on all wheels must be accessible during technical control. Any machine involved in an accident must be presented to Technical Control for re-inspection before being ridden again at the meeting. Youth – protective clothing must be worn by competitors when presented for Technical Control.

### 2.7.1 PRACTISING

At all Grass Track meetings controlled practising will be allowed on the course and each driver and passenger must complete at least two laps of practice to qualify for the event. Practice laps must be recorded.

### 2.7.2 PRACTICE STARTS

Practice starts are permitted provided they take place off the “racing line”, unless stated otherwise in the Supplementary Regulations for the event.

## 2.8 ON TRACK STARTS

The Start/Finish line should be positioned at 50% of the length of the straight. The starting gate stanchions must not compromise the run off area. There must be no more than eight solos or six sidecars on the start line.

## 2.9 METHOD OF STARTING

The method of starting shall be stated in the Supplementary Regulations. For National adult events a green light will be illuminated to indicate to riders that they are under Starter’s Orders. Any rider whose machine touches the starting tapes once under starter’s orders will be disqualified.

## 2.10 STARTER’S ORDERS

Only those riders/passengers in the starting area or on a grid will be deemed to be under Starter’s Orders. No other rider is subsequently permitted to start in a race.

## 2.11 DELAYING THE START

Any rider not prepared to start within two minutes after being called to the starting line will be disqualified from the race.

## 2.12 FALSE START

Any rider who in the opinion of the Clerk of the Course has caused a false start will be disqualified from that race.

## 2.13 FLAG SIGNALS

The following code of Flag Signals will be used where appropriate.

**National Flag:** Start.

**Black with Drivers Number:** That driver to STOP.

**Yellow:** Accident, slow down, driver must be prepared to stop. OVERTAKING STRICTLY PROHIBITED. Any rider judged to have taken unfair advantage by racing or attempting to overtake within the area controlled by the yellow flags will be considered guilty of unfair and/or dangerous driving and will be disqualified.

**Red:** Immediate STOP all drivers – return to the pits at a walking pace or as directed by the marshals.

**Green:** Course Clear.

**Yellow with Black diagonal cross:** Start of last lap.

**Chequered Black and White:** Finish.

Any additional flag signals will be stated in the Supplementary Regulations.

Only authorised Officials are permitted to use these flags.

All the above flags should measure not less than 750mm × 600mm.

#### **2.14 FINISH OF RACE**

The chequered flag will be displayed as the winner crosses the finishing line and will be kept flying thereafter until the last rider finishes the lap. No rider will be allowed to start a fresh lap after the chequered flag has been displayed. Thereafter riders crossing the line will be flagged off, their position being determined by the number of laps each has completed. To be classified as a finisher a rider must complete  $\frac{3}{4}$  of a four lap race or  $\frac{2}{3}$  of a six lap race within three minutes of the winner crossing the finish line.

A competitor who has qualified for a final but not completed race distance will be placed according to the number of laps completed, without the requirement to complete a minimum number of laps.

#### **2.15 FALSE FINISHES**

When a race has been indicated as finished by the display of the chequered flag before the required number of laps has been completed by the leading rider, the race must be declared null and void and re-run unless the leading rider had completed 75% of the scheduled number of laps, in which case the result will stand.

If the chequered flag has not been shown after the completion of the scheduled number of laps, the chequered flag shall be considered to have been shown at the completion of the scheduled number of laps.

#### **2.16 ACCIDENT INVOLVING DANGER**

If an accident has occurred and in the opinion of the Clerk of the Course it would be dangerous for the race to continue, he will stop the race and may order it to be re-run. The Clerk of the Course will exclude the rider(s) who he deems to be the primary cause of the race being stopped.

#### **2.17 STOPPAGE OF A RACE**

If a race is stopped before the race leader has completed  $\frac{3}{4}$  of a 4 lap race, or  $\frac{2}{3}$  of a 3 or 6 lap race, the race shall be re-run. If the race leader has completed the above race distances, ( $\frac{3}{4}$  of 4 lap race or  $\frac{2}{3}$  of a 3 or 6 lap race), before the race is stopped, the results can be declared at the discretion of the Clerk of the Course.

#### **2.18 RE-RUN RACES**

In the event of a race being re-run, the Clerk of the Course may permit any rider who has fallen either as a result of his having been fouled or because he had deliberately 'laid down' his motorcycle or has left the course in the interest of safety, to take part in the re-run. Any rider having been the primary cause of the stoppage, or not proceeding under mechanical power at the time of the stoppage, will not be eligible to take part in the re-run.

#### **2.19 LEAVING THE COURSE**

A driver who permits any of the wheels of his motorcycle and/or sidecar to cross the defined edges of the track will be reported to the Clerk of the Course who may disqualify that rider, unless such action was in the interests of safety or due to the action of another rider. Any rider or passenger who displaces the marking flags with either his motorcycle/sidecar or any part of his person may be excluded.

## 2.20 RIDING IN THE PITS

There shall be no riding of motorcycles in the pits. Where possible an area protected by a safety fence shall be provided to start machines.

## 2.21 OUTSIDE ASSISTANCE

If, during a race, a rider receives outside assistance, other than that provided by the organisers for the removal of himself or his machine from the course in the interests of safety, he will be excluded.

## 2.22 FOUL, UNFAIR OR DANGEROUS RIDING

The Clerk of the Course may discipline any rider who, in his opinion is guilty of unfair, foul or dangerous riding in accordance with 10.03.2.1 of the National Sporting Code of the ACU.

## 2.23 CHANGE OF MACHINE OR PASSENGER

A change of machine and/or passenger within a particular capacity class may be permitted at any stage of an event (including the re-run of any races) subject to the approval of the Clerk of the Course, providing that:

- a) The machine has been passed by the Technical Official.
- b) The passenger has an appropriate licence, has signed on, and has taken part in the official sidecar practice.

## 2.24 TIES

(Required for ACU Championship and National events, recommended for other events – if alternative method to be used, must be included in Supplementary Regulations)

### Intermediate/Semi Final Standings

- a. Count back
- b. Best position in the last heat that the riders met
- c. A ballot in the presence of a Steward

### Finals Where Points are Carried Forward

- a. Where riders tie on points after the Final, the best place in that Final will decide the overall result.

## 2.25 MEDICAL SERVICES

At least one ambulance must be present during all official practicing and racing, and if it is not possible for a second ambulance to be present, an auxiliary vehicle with a stretcher must also be available on the course during official practicing and racing.

At all Grass Track events, including official practice, a minimum of 4 × qualified First Aid personnel must be in attendance with full First Aid equipment including a stretcher.

**For events of National status and above** arrangements must also be made for 2 Doctors or 2 Paramedics, with appropriate equipment for racing, to be in attendance during racing and official practicing with TWO ambulances being available.

For further details, please refer to Medical Services on page 117.

**For events below National status** the attendance of a Doctor or Paramedic is strongly recommended.

All Paramedics must be registered with the Health Professional Council. Names of Paramedics should be obtained by an organiser prior to the event taking place and then checked on the following HPC website: <http://www.hpc-uk.org>.

The minimum equipment requirements for an Ambulance are as follows:

**Medical:** Stretcher – apparatus to immobilise limbs and vertebral column – oxygen supply – First Aid kit and materials.

**Technical:** radio communication – visible and audio signals.



(Note: Local hospital authorities must be advised prior to the event of the time and date of the meeting).

For definitions of Doctor, Paramedic, Ambulance and First Aid personnel please refer to the Medical Services section within this handbook. Paramedics must be registered with the Health Professional Council. Be aware that some Paramedics and St Johns Ambulance teams may not be able to carry morphine.

### **Concussion**

If a competitor is involved in an incident which results in him being diagnosed by the Medical Officer/Paramedic as suffering from concussion, the rider is not permitted to participate any further in that event.

Organisers are to notify ACU Head Office as soon as possible of any concussion injuries and then will subsequently:

- a) Place the rider on the ACU Stop List
- b) Inform Organisers of forthcoming events that the Rider has suffered a concussion injury and is therefore placed on the ACU Stop List
- c) Inform the Rider that he needs to see a Doctor and obtain a letter/doctor's certificate which confirms he is fit to resume competitive racing/participate in a practice/test session.

The recovery time for anyone diagnosed with concussion is as follows:

- a) Over 20 years: Excluded immediately and suspended for a period of nine days.
- b) 16–19 years: Excluded immediately and suspended for a period of twelve days.
- c) 15 and under: Excluded immediately and suspended for a period of twenty three days.

The rider is not permitted to ride during the obligatory suspended periods outlined above and then only once he is in possession of a doctor's certificate/letter after the suspended period has expired.

If a competitor has been injured on a Saturday and is suffering from concussion, and the Organiser is aware that the rider was intending to ride or is scheduled to ride somewhere else the next day, the Organiser will inform the Organiser of the event being held the next day so they are aware of the rider's injuries and as such he is prevented from participating in that event.

### **2.26 DOGS**

Whilst dogs are not discouraged from attending Off Road motorcycle sport events, they are to be kept on a lead and under control at all times. Owners are responsible for ensuring that any dog is kept under control and are responsible for clearing up any fouling that may occur.

## **SECTION 3 RIDERS**

### **3.1 HELMETS**

Helmets approved by the ACU bearing the current ACU approval stamp and in sound condition and properly fitted must be worn by all riders and passengers while practising and racing. Overseas riders may use helmets as approved by their own FMN or FIM. Cameras mounted on helmets will not be permitted to be used in Track Racing. For further information regarding helmets please refer to the Helmet section of this handbook.

### **3.2 PROTECTIVE CLOTHING**

In all races and official practice outer clothing made of leather or a substitute, substantially padded at the shoulders, elbows, hips and knees, and calf-length boots, and leather or suitable substitute material gloves, must be worn by both riders and passengers. Racing suits should be one piece or effectively joined when worn to form one piece. Any other racing suits must meet the standards required for leathers. Where non-leather materials are used they should have the following characteristics equivalent to leather:

- i) Fire retardant ability
- ii) Resistance to abrasion

- iii) Coefficient of friction against track surfaces
- iv) Perspiration absorbing ability
- v) Be nontoxic and non-allergic
- vi) Fabric must not melt

The clothing manufacturer is responsible for ensuring that the products and materials that carry his name conform to these rules. Kevlar suits are approved ONLY if worn with padding or a padded inner suit. Nylon suits will only be approved if worn with padding or a padded inner suit. It is advised that motocross jerseys should only be worn with padding that will provide protection against abrasion to the body and arms and that motocross jeans should only be worn with padding to the hips and knees.

The minimum requirements for the footwear of passengers shall be leather ankle boots, minimum height 200mm. Goggles, and spectacles if worn, shall be of a non-shatter proof material.

**Rigid Tear Offs** – must have rounded corners to avoid causing injury when discarded.

**Youth** – Tinted goggles/visors only allowed with permission of the Clerk of the Course and Technical Official at Technical Control. Youth protective clothing should comply to the same standards as for adults.

**Back Protectors.** Competitors in all classes are required to wear commercially manufactured back protection during both practice and racing.

### 3.3 IDENTIFICATION DISCS

All riders and passengers, including youth competitors, are required to wear identification discs around the neck or the wrist during racing and practising. The disc must bear the wearer's full name and date of birth. String/wool or any other non-breakable material must not be used around the neck.

### 3.4 JEWELLERY

Competitors are advised not to wear hand, face or body jewellery/piercings which could prove hazardous in the event of an accident. The mouth should be kept clear of anything likely to cause a blockage of the airway in the event of an incident, e.g. chewing gum. This includes removing dentures.

### 3.5 FIRE EXTINGUISHERS

All competitors, with the exemption of those who have travelled to an event on the machine on which they are competing, must have a 2kg (minimum) dry powder fire extinguisher available for immediate use. If a 'closed vehicle' is being used the extinguisher must be fitted adjacent to, or on the inside of the working door. In the case of a shared vehicle the other competitor's extinguisher(s) should also be visible, or, the fitted extinguisher(s) must be of a proportionately larger capacity.

### 3.6 LICENCES

- a) **FIM & FIM EUROPE Championship Licences.** The Track Racing Committee will confirm the competitors who qualified and are eligible for these licences. The holders will be automatically entitled to hold an International Non-Championship Licence.
- b) **International Non-Championship Licence.** To qualify for an FIM Non Championship licence, a competitor must finish in the top 20 (Solo) or top 10 (Sidecar) in the appropriate British Masters or National Championship. The FIM Non Championship licence is valid for a period of **two years** commencing on the 1st January following the date of qualification. The Track Racing Committee reserve the right to issue this licence to competitors in exceptional circumstances.
- c) **Licence Upgrading.** To upgrade to a National Licence drivers must obtain signatures from the relevant Clerk of the Course to demonstrate that they have finished in 6 finals at lower level events. Sidecar drivers and passengers wishing to upgrade to a National Licence must obtain signatures from the relevant Clerk of the Course to demonstrate they have finished in 6 finals at lower level events in the same category that they are seeking a national licence for.

- d) **Lapsed Licences.** Any competitor wishing to renew a licence which requires qualification and the licence has been expired for more than 3 years will be issued with a Restricted Licence.

## SECTION 4 TECHNICAL

### 4.1 SPECIFICATION OF MOTORCYCLE

Motorcycles of Solo Category 1, Group A1, Sidecar Category 1, Group B1 (a, b, c) must comply with the following discipline requirements in addition to those of the National Sporting Code Appendix D. Machines originally designed for Enduro, Motocross, and Trials competitions (as defined in the respective regulations) are permitted in race meetings but may not be used in the same races as Track Racing motorcycles, but may be included on the same permit.

### 4.2 BRAKES

Motorcycles in Category A(1) and A(2) (Solos) must comply with the following:

- 250cc, 350cc and 500cc Track Racing motorcycles used in adult competitions must not be fitted with brakes or decompressors.
- All other motorcycles used in adult competitions to be fitted with at least one effective brake. Motorcycles in Category 1 Group B (a, b) must be equipped with at least one effective brake operating on the motorcycle wheels. Motorcycles in Category B1(C)
- Brakes are not permitted on 500cc sidecar motorcycles.

For Youth Competitions, all machines must be fitted with an effective brake, with the exception, machines used in the International 125cc and 250cc Four Stroke class competitions where brakes are not allowed.

Machines without brakes CANNOT COMPETE in the same races as machines with brakes.

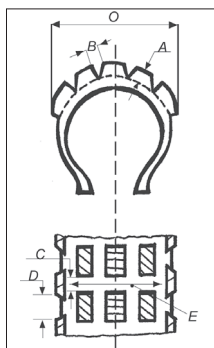

### 4.3 TYRES

Except for the prohibited use of tractor pattern tread tyres there is no restriction as to the type of tyres which may be used for solo motorcycles, other than as may be laid down in the Supplementary Regulations. The tread depth and spacing of tyres fitted to the driven wheel of Groups B (a, b) must not exceed the dimensions specified for trials tyres refer to diagram. The overall width, measured at wheel spindle height must not exceed 150mm. Tread depth (A) must not exceed 13mm. All tread blocks in the same circumference must be of the same depth. The space between the tread blocks (B) must not exceed 10mm across the tyre or 13mm in a circumferential direction (C). The space between the shoulder blocks (D) must not exceed 22mm. The space across the tread (E) must not extend completely across the tyre measured at right angles to the tyre wall unless broken by a block. All main tread blocks must in principle be parallel with or at right angles to the tyre axis. (The tyre must have the same appearance if reversed and conform in principle with these diagrams). The tread pattern of the tyre must not be modified.

### 4.4 MUDGUARDS AND WHEEL PROTECTION

Category 1, Group A and B motorcycles must be fitted with two mudguards giving protection to the driver. The rear mudguard must extend laterally beyond the tyre and cover at least 35 degrees of the upper front quadrant of the rear wheel, and must extend to 5 degrees or more behind a vertical line running through the rear wheel spindle and must extend to the full width of the tyre. The Clerk of the Course may permit the removal of the front mudguard if conditions make this desirable. If cast or welded wheels are used for all types of Track Racing a protection must be provided by enclosing the spokes with solid discs. The sidecar wheel mudguard must extend to the full width of the tyre.

For all solo machines FIM Homologated Dirt Deflectors may be used. The lower edge shall be 35mm maximum from the track surface over an equal distance. To measure the tension by the machine dirt deflector, a vertical balance shall be used to measure the equivalent minimum pre-load of 8kg for the dirt deflectors used for Long Track and Grass Track Solo Machines and 6kg for 1000cc sidecars. The vertical balance must be attached to the outer edge of the dirt deflector holder plate in line with the centre of the rear tyre. All measurements are taken with the machine in a vertical position, with the tyres normally inflated without a rider.

#### **4.5 WHEEL RIMS**

The modification by drilling to the wheel rims is prohibited other than for spokes, valve, security bolts or tyre retention screws. If the rim is modified for bolts, screws etc. they must be fitted.

#### **4.6 ALL CONTROL LEVERS**

Ball ended levers (all machines) 16mm min diameter.

#### **4.7 FOOTRESTS AND HANDLEBARS**

The footrest for the driver must be positioned to give easy access to any control pedal. The ends of the footrest must be rounded with a spherical radius of not less than 8mm viewing from front and end of footrest. The ends of the handlebars on all motorcycles shall be rounded or otherwise protected. When light alloy handlebars are used, the distance between the two extremities of the clamping area (or of the two clamps) must not be less than 120mm and handlebar clamps must be very carefully radiused and engineered so as to avoid fracture points in the bar.

Handlebar width (solo machines)

85/125                    Min 650mm Max 850mm

250/350/500          Min 700mm Max 900mm

#### **4.8 FRONT ENGINE PLATES SOLO – MACHINES**

Where appropriate, the void between the front engine plates of solo machines below the dirt shield, if fitted, must be covered with a permanently fixed shield or plate.

#### **4.9 OPEN TRANSMISSION GUARDS**

The primary transmission must have a fully enclosed guard. The cutting of the guard is only permitted to expose the clutch pressure plate and allow adjustments to the clutch springs. An additional protection must be provided to prevent a broken primary chain from flying upwards. This can be provided by either a fully enclosed steel chain guard or, if a plastic chain guard is used, a steel bolt of 10mm minimum diameter, placed outside the bottom rear quadrant of the clutch sprocket. This bolt, if damaged, must always be completely replaced. On all machines chain guards must be fitted to cover the entry to the gear box and rear wheel sprockets.

#### **4.10 IGNITION CUT-OUTS**

An ignition cut-out operated by a lanyard which disables the machine in the event that the driver dismounts must be fitted to all machines. Cut-outs must function when the lanyard is pulled from any direction. The lanyard must be non-elastic. Coiled telephone cable or similar materials are not permitted. The cut-out must operate on the low voltage circuit and be fail safe when operated. In addition, any part of the cut-out which remains live after actuation must be shrouded in order to prevent accidental contact re-establishing the current flow. The use of the handlebars or front forks as part of any circuit is not permitted. The cut-out lanyard must be attached to the rider/mechanic's wrist whenever the engine is running including push starting the machine and warming up the engine. Cut-outs will be checked prior to practice. In cases where there are time limitations or noise constraints, cut-outs will be tested as the machine enters the track for first practice.

#### 4.11 CARBURETTORS OR OTHER AIR INPUT CONTROL INSTRUMENTS

500cc solo machines must be fitted with one carburettor with a maximum choke size of 34 + 0.1mm circular shape.

#### 4.12 SUPERCHARGERS

The use of superchargers and turbo chargers on solo machines is prohibited.

#### 4.13 CHASSIS CONSTRUCTION

The use of titanium nuts and bolts is not permitted. A dimension increase may be necessary when ferrous fasteners are replaced by non-ferrous fasteners.

#### 4.14 EXHAUST SYSTEMS AND CONTROL OF EXHAUST SOUND LEVELS

**Solo** – The exhaust system of a solo machine must not extend beyond the outer circumference of the rear tyre. Between the silencer and the tyre a maximum gap of 60mm must not be surpassed. The exhaust fumes must be discharged from the system horizontally and parallel to the centre line of the machine. The exhaust pipe of a solo track racing motorcycle must be fixed to the cylinder head and frame with a minimum of three clips (the point of fixture at the cylinder head is considered as one clip). The diameter of the exhaust pipe must not exceed 50mm diameter or an equivalent area and must remain constant up to the silencer. The outlet area of the silencer must remain constant over a length of 50mm and must not exceed 45mm or an equivalent area.

**500cc Solo and Sidecar Machines** – must use a 2010 FIM Homologated silencer. The only exception are machines using engines not designed for Track Racing where an alternative silencer must be used and will be subject to sound control using the new FIM 2 metre Max method of testing.

**250cc and 350cc Solo Machines** – must use either the 2010 or 1995 FIM Homologated silencer.

The only exception are machines using engines not designed for Track Racing where an alternative silencer must be used and will be subject to sound control using the FIM 2 Metre Max Sound Levels.

**Pre 75 and Upright Solo Machines** – must use either the 2010 or 1995 FIM Homologated silencer.

The only exceptions are machines using engines not designed for Track Racing where an alternative silencer must be used and will be subject to sound control using the FIM 2 Metre Max Sound Levels.

**1000cc Sidecar Machines** – will be subject to sound control using a 'Ride By' method with a maximum sound level of 85dBA. The sound meter will be positioned in the middle of the centre green opposite the finish line, the sound meter will face the finish line or directly opposite on the back straight if the wind is blowing towards the sound meter.

If a machine is over the maximum sound level and the rider disputes the sound meter reading, the machine will be tested to the '2 Metre Max Method'. If the rider refuses to undertake the '2 Metre Max' sound test or if the machine cannot be tested to '2 Metre Max' sound method satisfactorily (e.g. the engine will not rev to near the maximum revs) the Ride By Sound reading will prevail without appeal.

**200cc and Lower Machines** – will be subject to sound control using the current ACU sound control method.

**For Sidecar Category B1(c) 500cc** exhaust systems see specification 4.16(b).

**All Machines** – The outside shell of a silencer must form one integral unit in order to prevent any parts being dropped during a race. The end of the pipe must be cut at a right angle. The silencer must be fixed to the frame with at least one clip. In addition, for reasons of safety, a second flexible coupling must be fitted from the first third of the silencer to the frame (for example: a steel cable of at least 3mm diameter). The use of intermediate expansion boxes on two-stroke machines is permitted.

#### 4.15 SPECIFICATION OF THREE WHEELERS CATEGORY 1

All motorcycles in Group B1 (a, and b) shall comply with the following:

- a) The three road wheels shall be each of at least 400mm (16") in diameter measured over the outside of the tyre.

- b) Where wheels are not wire spoked they must be enclosed with a disc.
- c) The wheel track, or lateral distance between tracks, shall be at least 800mm (32").
- d) Chains: The top and bottom runs of the drive chains and points of connection must be shielded.
- e) A passenger must be carried in addition to the rider.
- f) All sidecars must be on the left hand side of the motorcycle except where special dispensation has been granted for races confined to sidecars affixed to the right hand side of the motorcycle.
- g) All sidecars must be rigidly fixed to the motorcycle. On level ground the maximum incline of the sidecar wheel must not exceed 25 degrees. The maximum incline of a Class B1 (a) (1000cc) motorcycle must not exceed 5 degrees from the vertical. The sidecar wheel must be completely covered on the outside by a disk extending to the wheel rim. No light alloy bolts shall be used in the attachment of the sidecar or sidecar wheel.
- h) The sidecar wheel may be covered by a fairing. If such a fairing is fitted it must be constructed of fibreglass, plastic or similar material and must not provide a danger to any competitor. No part of any sidecar fairing may extend beyond a vertical line drawn through the rear edge of the back tyre. If the sidecar wheel is to be enclosed by a fairing it must be contained within a continuous 25mm horizontal supporting bar, fixed rigidly to the sidecar platform at sidecar floor height. On the right hand side of the machine any single projection within the diameter of the rear wheel and tyre must not exceed 100mm (4") measured horizontally from the outside of the rear wheel fork slot. Where a single projection as an extension to the rear spindle is used, this must have a minimum diameter of 25mm, be ball-ended and covered with a rubber ferrule.
- i) The maximum capacity of machines permitted in sidecar races shall be: Class B1 (a and b) maximum 1006cc, unsupercharged, 650cc supercharged maximum.
- j) For all 1000cc Sidecar machines – Class B1 (a and b) – dirt deflectors must be used. Where a machine is fitted with a dirt deflector it will replace the mudflap.
- k) No part of the passenger hand-rail on a sidecar may be less than 255mm from the outer edge of the sidecar (this includes the wheel and wheel arch).
- l) The front of the sidecar chassis must allow reasonable lift of the rear wheel. Where foot boards are fitted to the motorcycle, there must also be reasonable lift of the sidecar wheel before the foot boards foul the ground.
- m) Protection for the passenger must be provided on three-wheelers from the rear wheel, the primary and final drive chains of the motorcycle and from the sidecar wheel.
- n) The front and rear wheels, when measured from the centre lines of each wheel at ground level (in direction of forward travel and with correctly inflated tyres) may be displaced by a maximum of 75mm.

#### 4.16 SPECIFICATION OF THREE WHEELER CATEGORY B1(C) 500CC

- a) **General Specification.** For all races, only single cylinder 4-stroke engines are allowed. The maximum capacity is 500cc, 4 valves maximum fitted with one carburettor, maximum diameter 38mm and one spark plug.
- b) **Exhaust System.** The exhaust must not extend beyond the outer circumference of the rear tyre and must not end further forward than the centre of the rear wheel. Between the silencer and the tyre there must be a maximum gap of 60mm. On a sidecar machine the exhaust must discharge horizontally and towards the rear, at a maximum angle of 30 degrees to the axis of the machine, and at the end be of a constant diameter over a distance of 50mm. FIM homologated silencers must be used, in line with the current sound control regulations and a FIM approved heat shield must be fitted.
- c) **Brakes.** Brakes are not permitted on 500cc sidecar motorcycles.
- d) **Footrests.** For Track Racing sidecars the footrest on the opposite side to the sidecar must be protected at the front by a crash bar connected to the frame so that injury or breakdown to

other participants is prevented. The footrest must be fitted at a height of at least 150mm from the ground.

- e) **Mudguards & Wheel Protection.** For 500cc sidecars, the mudguard of the rear wheel and the mudguard of the sidecar must extend within 200mm from the ground. Protection from the sidecar wheel and the rear wheel for the passenger must be provided down to the level of the sidecar platform. The sidecar wheel must either be completely covered by a disc extending to the wheel rim, or the sidecar mudguard must extend downwards on the outside of the centre of the wheel spindle.
- f) **Tyres.** No specification for front and sidecar tyres. For the rear tyre the overall width must not exceed 100mm and the only tyres allowed are those with Track Racing, Speedway or Trials tyre tread pattern.
- g) **Wheels & Rims.** Front wheel: Minimum rim diameter 18", minimum diameter of wheel spindle 15mm, solid steel shaft permitted only, minimum diameter of spokes 3.5mm M4 steel, spoke facing must cross twice. Rear wheel: Minimum rim diameter 18", maximum rim diameter 22", minimum diameter wheel spindle 17mm, solid steel shaft permitted only, minimum diameter of spokes 4mm M4 steel, spoke facing must cross twice. Sidecar wheel: Maximum rim diameter: 16". Maximum wheel inclination of 30°, measured from the vertical to the inside (controlled by angle measuring instrument and spirit level). Position: One-sided wheel spindle diameter of 25mm minimum at the point of the highest moment of deflection; solid steel; or, diameter of 15mm if supported on both sides of the wheel. The sidecar wheel spindle must not be welded in position. It must be screwed on, for example, by collar or clamp, with at least three M8 screws. The minimum length of the clamp is 100mm. For construction using a clamp, protective devices against the loss of the component or failure of the clamp must be provided. Clamp construction in two places is forbidden. All wheel shafts must be secured by a nut with a secondary safety device e.g. split pin, R clip or circlip.
- h) **Sidecar Specification.** The minimum ground clearance at the front edge of the sidecar platform is 150mm. The ground clearance of a laden sidecar (with a rider and passenger) must be no less than 100mm at any point. The distance between the tracks left by the centre lines of the rear motorcycle wheel and the sidecar wheel must be at least 800mm and not more than 1100mm. On the opposite side of a 500cc sidecar, the exhaust pipe must not extend more than 330mm from the centre of the machine. On the sidecar side, the exhaust pipe must not extend beyond the width of the sidecar. The furthest extremity of the exhaust pipe must not exceed the vertical line drawn at a tangent to the rear edge of the rear motorcycle tyre or the rear edge of the sidecar platform whichever is shorter. The outside of the 500cc sidecar wheel shall be provided with horizontal tubular protection (minimum tube diameter 25mm) fixed at the same height as the sidecar wheel spindle. No component shall protrude beyond this protection. The inclination angle of the motorcycle must not exceed 15°.

#### 4.17 ADDITIONAL SIDECAR CLASSES

(detailed regulations available from the ACU Office upon request)

1. Pre 1978 Class.
  - a) For machines fitted with British made twin cylinder engines initially designed for mass produced road bikes. (up to 650cc supercharged and 1000cc naturally aspirated) (for 650cc machines actual maximum capacity will be based on manufacturer's standard rebore sizes)
  - b) Chassis and running gear to be based upon the type commonly in use pre 1978.
  - c) All current safety and environment requirements to be respected.
2. 500cc Twin Cylinder Class.
  - a) For machines fitted with parallel twin cylinder engines initially designed for mass produced road bikes (naturally aspirated)
  - b) Chassis to be based on current requirements.

- c) All current safety and environment requirements to be respected.
- 4. 250cc Junior Class.
  - a) For machines fitted with four stroke engines.
  - b) Chassis to be based on current requirements, but dimensions may be amended to suit age and weight of users.
  - c) All current safety and environment requirements to be respected.

#### 4.18 TRACTION CONTROL

The forward motion of a motorcycle must be controlled by the rider only, and regulation of speed shall be through the use of throttle, clutch, gears and brakes when fitted. Any other form of control is not permitted.

#### 4.19 FUEL

Fuel may be methanol or unleaded petrol. Please refer to the ACU and FIM fuel regulations for physical properties, fuel test costs, and penalties for non-compliance. Power boosters and octane boosters are forbidden. Fuel may only be retailed from a point of a minimum of 7 metres from any other vehicle. The area must be roped off and the retailers must display 'No Smoking' and 'No Naked Lights' signs, in addition to any other requirements requested by the local authorities. Fuel must only be dispensed in clearly labelled containers. No Smoking – this also applies to all Electronic Cigarettes. Mobile phones should not be used when refuelling machines.

#### 4.20 OIL CATCH TANKS

Must be fitted to all four stroke machines using a total loss lubrication system and must be emptied after each race.

#### 4.21 NUMBER PLATES

Whenever number plates are required to be used at an event they will be three in number and must comply with the following requirements. Both classic and pre-75 machines may be granted a dispensation to this rule. Number plates must be of durable construction with the minimum dimensions height 235mm × width 285mm. The front plate must be rectangular with 50mm radius to the corners. The plates must be flat or slightly curved (not more than 50mm from the true plane) and must not be otherwise bent or obscured in any way. One plate must be carried forward and not more than 30 degrees from the vertical and the others must be facing outwards and vertical (one on each side of the machine). Side facing plates can be oval. They must be so fixed that they are clearly visible and not obscured by any part of the machine or by the driver or passenger when in the riding position. **It is the responsibility of the competitor to ensure that racing numbers are clearly visible for lap scorers.** The minimum dimensions of the figures must be: height 140mm, width 80mm, width of stroke 25mm and the space between any two figures 15mm. The number plate size relates to a two digit number. Should a three digit number be used then an increase in the size of the plate will be required. The figures must be legible and both figures and background must be in a 'matt' (non-shiny) colour. The colours shall be as follows:

##### Front and Side Number Plates – Background Colour and Number colour

Solos up to 50cc White | Black  
 Over 100cc to 125cc Black | White  
 Over 126cc to 250cc Green | White  
 Over 251cc to 350cc Blue | White  
 Over 351cc to 500cc Yellow | Black  
 Over 500cc to 1300cc White | Black

##### Three wheelers

Class B1c Yellow | Black  
 Class B1a, B1b Black | White



Where yellow, green or blue are required the colours shall comply with BS4800: 1972 as follows:  
Yellow 10E526 Green 14E53 Blue 18E53.

Any other number plate or any marking on the motorcycle that might be confused with a number plate must be removed before the rider is allowed to start.

**Streamlining** – Streamlining is NOT permitted on any Solo machine. Streamlining is defined as any addition to the handlebars or to the frame of the machine, the effect of which is to shield the rider's arms, legs or body from the air stream.

#### 4.22 QUADS

Grass Track Quads are limited to a maximum engine capacity; a two stroke engine quad should not exceed 550cc. Whether two stroke or four stroke the engine must have no more than two cylinders up to 550cc. The maximum engine capacity for a four stroke engine quad should not exceed 700cc and be single cylinder. Quads eligible for the 250cc class are allowed a 10% oversize but are not allowed to exceed 275cc. Motocross riding gear must be worn at all times. Track safety roping is to be set out as in accordance with the Grass Track sidecar safety roping regulations. Lanyard cutouts must be used.

**Youth – Quads are not permitted in youth events without agreement from the Track Racing Committee.**

For Quads a third number plate must be fitted running parallel with the machine at the rear, readable when facing the side view of the machine. The mounting bracket must not exceed 25mm in a vertical plane from the mounting point.

All other specifications as in Quad/ATV Motocross Standing Regulations and National Sporting Code Appendix D.

#### 4.23 CLASSIC PRE-75 SOLO GRASTRACK MACHINES

These guidelines are for solo machines in accordance with equipment which was in common use up to 1975.

- a) **Standing Regulations.** All machines must comply with the Standing Regulations for Grass Track racing as given in the current edition of the ACU handbook with the exception of the following:
  - b) **Frame.** The frame should ensure that the engine is mounted in a near upright or vertical position. The rear suspension, if fitted, should incorporate a swinging arm with suspension units mounted on each leg of the swinging arm and onto the rear sub frame. Monoshock rear suspension is not permitted. Only telescopic style front forks are permitted. Leading link style forks are not permitted.
  - c) **Four Stroke Engines.** The engine will have one inlet and one exhaust valve per cylinder. The inlet port of the cylinder head must be angled towards the right hand or left hand side of the machine. Central carburettor cylinder head design will not be permitted. On a pre unit construction type engine the lubrication system will be total loss type with an oil catch tank fitted as per Grass Track Technical Rule 4.19. On a unit construction type engine a recirculatory oil system will be permitted.
  - d) **Two Stroke Engines.** The engine will be of air cooled design and be of a type commercially available up to 1975. Water cooled engines not permitted.
  - e) **Carburettor and Ignition System.** No restriction.
  - f) **Transmission System (gearbox and clutch).** No restriction.
  - g) **Mudguard.** Number plates and dirt shields etc. In keeping with the styles and types available of the period (plain designs and colours are preferred)
  - h) **Wheel Sizes.** No restriction.
  - i) **Brakes.** As per Grass Track Standing Regulations rule 4.2.

The object of the above guidelines are to ensure that all Club Officials and competitors are aware of the construction requirements so that the possibility of a dispute at an event is reduced. It is

recognised that certain parts will be of modern manufacture, this will be accepted as long as the above guidelines are adhered to.

#### 4.24 POST-CLASSIC PRE-1990 UPRIGHT SOLO GRASSTRACK MACHINES

These guidelines are for solo machines in accordance with equipment that was in common use between 1976 and 1990.

- a) **Standing Regulations.** All machines must comply with the Standing Regulations for Grasstrack racing as given in the current edition of the ACU handbook with the exception of the following:
- b) **Frame.** The frame should ensure that the engine is mounted in a near upright or vertical position. The rear suspension, if fitted, should incorporate a swinging arm with suspension units mounted on each leg of the swinging arm and onto the rear sub frame. (MONOSHOCK REAR SUSPENSION IS NOT PERMITTED) Both telescopic style and leading link type front forks are permitted.
- c) **Four Stroke Engines.** The engine will be of a type commercially available between 1976 and 1990. The engine will have two inlet and two exhaust valves per cylinder. The inlet port of the cylinder head may be angled towards the right hand or left hand side of the machine or mounted centrally from the cylinder head.  
The engine the lubrication system may be either a recirculatory system or a total loss system. If the engine is a total loss system then an oil catch tank must be fitted as per Grasstrack Technical Rule 4.18.
- d) **Four Stroke Engine Carburettor.** Must have a maximum choke/venturi diameter of 34mm.
- e) **Two Stroke Engine.** The engine will be of a type commercially available between 1976 and 1985. Both air cooled and water cooled engines are allowed.
- f) **Two Stroke Engine Carburettor.** Must have a maximum choke/venture diameter of 38mm.
- g) **Ignition system.** No restriction.
- h) **Transmission system (gearbox and clutch).** No restriction.
- i) **Mudguard.** Mudguards, number plates and dirt shields etc. will be in keeping with the styles and types available of the period.
- j) **Wheel sizes.** No restriction.
- k) **Brakes.** As per Grasstrack Technical rule 4.2 (ACU Handbook).
- l) **Silencers.** All machines must adhere to the current ACU Sound Regulations, as set out at 4.14 above.

The object of the above guidelines are to ensure that all Club Officials and competitors are aware of the construction requirements so that the possibility of a dispute at an event is reduced. It is recognised that certain parts will be of modern manufacture; this will be accepted as long as the above guidelines are adhered to.

#### 4.25 FORMULA GRASS TRACK (FORMERLY BANTAM GRASS TRACK)

Unless stated – Machine specification is as ACU Grass Track Standing Regulations.

##### Honda Engine

A Standard street legal 100cc–125cc single cylinder, two valve 4 stroke. Standard specifications is as manufacturers handbook i.e. bore 56mm, stroke 49.5mm comp ratio 9.5:1 etc. No engine designed for off road to be used e.g. XR range. No interchanging of parts that would alter standard specification of engine re: handbook. Recommended models CG. CB. XL. RS.

- a) **Gear Box.** Standard ratios only. No close ratio gears. Gears to be fitted as standard with model. No pinions to be left out of gear box, the full cluster must be fitted.
- b) **Ignition.** Any type including electronic. Rotor & stator plate may be removed.
- c) **Honda Engine.** A Standard street legal 100cc–125cc single cylinder, two valve 4 strokes. Standard specifications is as manufacturers handbook i.e. bore 56mm, stroke 49.5mm comp ratio 9:5:1 etc. No engine designed for off road to be used e.g. XR range. No interchanging of

parts that would alter standard specification of engine re: handbook. Recommended models CG. CB. XL. RS.

- d) **Carburettor.** Any make, model or size. Reed valves not allowed.
- e) **Fuel.** Petrol – Normal pump grade. Methanol is not allowed.
- f) **Tyres** Grass Track/Speedway/Trials pattern tyres only. Trials tyre pattern as ACU handbook. On wheels under 18" in size – Trials type tread must be used. Use of Motocross type tyre is prohibited. Maximum tyre width is 3.75 inches size to be displayed on tyre. Not tyre cutting in any form will be allowed.
- g) **Frame.** Forks and brakes as per current ACU Regulations.
- h) **Wheels and Hubs.** Any make – 22" Max rear. 23" Max front. Front wheel must not be smaller than the rear.
- i) **Classes and Number Plate Colours**
- i) **Plate Colour Number Colour**
- i) **Classes and Number Plate Colours**

	Plate Colour	Number Colour
Cadets 6–9 years	White	Black
Cubs 9–12 Years	Red	White
Juniors 12–16 Years	Green	White
Seniors Over 16 Years	Black	White
- j) **Promoting Clubs,** Wrekin BGTC Manchester BGTC and Whitchurch MCC.

#### 4.26 INTERNATIONAL 125CC FOUR STROKE SPECIFICATION

International 125cc and 250cc four stroke specification refer to current FIM/FIM EUROPE technical specification. These classes will run without brakes. Other than events run to FIM/FIM EUROPE rules brakes must be fitted. Braked and non braked machines must not compete in the same race. The specification of machines in these classes will be in accordance with FIM Rules which are available from ACU Head Office.

## SECTION 5 SAND/BEACH RACING

As per Grass track Standing Regulations with the exception of:

- Maximum 12 where on-track start
- MX classes – refer to MX Standing Regulations
- MX classes to also include Enduro Machines

### ROAD MACHINE CLASSES

- Machines must have original frame and engine. Position can be changed and any unwanted brackets removed.
- Any swinging arm or suspension can be used but suspension type fitted to original machine must remain the same i.e. Machines fitted with units such as cantilever or pro-link, for example, must retain this original type although the make can be changed.
- Machines must retain their original fuel tanks, although a smaller tank that is in keeping with the type is permissible.
- Internal engine modifications allowed but external appearance must remain.
- 1mm oversize allowed for rebores; any carburettors or ignitions can be used.
- Enduro machines are not permitted in the road bike class.

### THREE WHEELER CATEGORY 1. GROUP B1 (A, B)

- Maximum Capacity of sidecars 1040cc (to accommodate FIM Sidecar Speedway regulation machines).
- Supercharged up to 650cc. 651cc to 1040cc – not supercharged.

## SECTION 6 SHORT TRACK

- 6.1 **Direction of racing.** Short Track Racing will take place on an oval circuit and will run in an anti-clockwise direction.
- 6.2 **No of riders.** There will be a maximum of twelve riders on the track in any race or practice session.
- 6.3 **Practice.** The practice session at the beginning of the meeting is compulsory for all riders.
- 6.4 **Race Distances.** The duration of races will be as follows: 6 laps for heat races, 8 laps for last chance/semi finals, 12 laps for the grand final.
- 6.5 **Time Penalty.** Any rider not at the start line within 2 minutes of being called will be excluded from the race.
- 6.6 **Starting Infringement.** If a rider touches the tapes or jumps the start, the referee will place them 25 metres back from the start line.
- 6.7 **Flags and Signals.** Riders must obey all signals given to them on the track.  
 Chequered Flag – The finish of a race or practice sessions.  
 Yellow Flag. – Danger in this section of the track, overtaking is prohibited.  
 Red Flag or Red Light – The practice or race is being interrupted. Riders must slow down, return to the pits and await further instructions from the Clerk of the Course.

## SECTION 7 SHORT TRACK TECHNICAL REGULATIONS

The basis for the specification will be Motocross, Enduro, Supermoto and Dirt Track machines.

- 7.1 Engine Displacement. 2 stroke 125cc to 500cc, 4 stroke 250cc – unlimited.
- 7.2 Besides the compulsory adjustments, alterations may be applied to the frame and the appearance of the machine.
- 7.3 The front forks must not protrude more than 5cm above the upper attachment of the suspension.
- 7.4 The rear wheel must be able to stop instantly, so an efficient braking system on the rear wheel is mandatory.
- 7.5 Front wheel brakes are prohibited and all the components relating to a front brake must be removed.
- 7.6 Only the following tyres are permitted: Speedway, Supermoto wet tyres and cut slicks, Dirt Track tyres and “for highway use” Trail tyres. Motocross and Enduro rear tyres are not permitted. As a rule, the block tread pattern should have straight sides (not tapered) and the gap between the blocks should be not more than half the width of the block, i.e. 10mm block, 5mm gap.
- 7.7 The rear sprocket should be guarded with a shark fin type protector.
- 7.8 The gearbox sprocket must be suitably protected.
- 7.9 Only fuel that can be purchased from a roadside petrol station is permitted.
- 7.10 A Lanyard type cut-out must be fitted to all machines.
- 7.11 Foot pegs should be in their original position on the frame or no lower than the frame itself.  
Both foot rests should be an equal height from the ground and in line with each other.
- 7.12 The noise level of any machine must not exceed 89dBA at 2 metres.

## SECTION 8 YOUTH COMPETITOR REGULATIONS

The following regulations apply to youth competitors only.

### 8.1 ORGANISING PERMITS

An application for a permit to organise a competition shall be made on the appropriate form and sent to the appropriate Permit Issuing Officer as per the National Sporting Code. Permits for events where revenue is to be obtained from the general public will only be issued if the proceeds are donated to charity, a Steward must also attend any such meeting. If revenue is to be obtained from the general public, it must be clearly stated when applying for a permit. Additional insurance must also be taken out and only events of National status and above will normally be granted permission.

## 8.2 JOINT YOUTH/ADULT EVENTS

Youth classes may be included in adult events of below National status. The practice and racing for Youth classes must be run separately from the Adult classes and the age groups also separated. Adult clubs promoting joint events shall organise these under a joint permit, issued by the local Centre.

## 8.3 ADVERTISING

Commercial advertising in connection with Youth competitors in the press or in any publication is not permitted. Approval must be obtained from the ACU Headquarters, before any club/rider appears on TV or any other media.

## 8.4 RESPONSIBILITY FOR YOUTH ENTRANTS

The parent or guardian must accompany a Youth entrant to a meeting and stay for the duration that the rider is present. A rider deemed unfit by First Aid personnel will be withdrawn from the meeting.

## 8.5 AGE GROUPS, ENGINE CAPACITY AND NUMBER PLATES

When a rider reaches the maximum age for his or her group, they may continue in that group until the end of the calendar year, or upgrade on his or her birthday.

No rider may compete before his/her 6th birthday. Riders may compete until the end of the year in which their 18th birthday falls. A rider may be upgraded to compete in Adult competitions on or after his/her 15th birthday, up to a maximum capacity of 350cc and may only revert to Senior Class Youth competition. There are no restrictions to the type or level of youth event that a rider may enter.

All riders must be capable of sitting on their machines at the start line (unaided) with the machine in an upright new line position with one foot firmly on the ground and the other on the footrest.

Production Motocross machines will not be allowed in any other Grass Track class apart from the Cadets which must not exceed the stated capacity.

For FIM Gold Trophy meetings and FIM EUROPE European Cups the minimum for each meeting starts on the competitor's minimum age birthday. The maximum age finished at the end of the year in which the competitor reaches the maximum age.

Youth riders are limited to 350cc engine size. At joint Adult/Youth events, a rider must specify which class he/she will enter, and cannot ride Youth and Adult at the same event. The maximum engine capacity sizes as stated in the table below apply to Youth Grass Track with the exception that Auto 50cc fixed geared machines cannot be ridden in the same class as geared machines.

For Quads refer to Motocross 2.2 on page 133.

Class	Capacity – Engine Type + Wheel Size (if applicable)	Age on 1st January	Number Plate Background Colour	Number Colour
Auto Cadet	50cc Fixed Auto	6–7 years	White	Black
Cadet	65cc–2 stroke	6–8 years	Black	White
Junior 65cc MX	65cc–2 stroke 110cc–4 stroke	7–10 years	Black	White
Inter 85cc MX	85cc–2 stroke 150cc–4 stroke 14" rear 17" front	9–12 years	Red	White
Senior 85cc MX	85cc–2 stroke 150cc–4 stroke 16" rear 19" front	11–15 years	Green	White
Junior	100cc–2 stroke 200cc–4 stroke	9–11 years	Red	White
Intermediate	150cc–2 stroke 250cc–4 stroke	12–14 years	Yellow	Black
Senior A 250cc	250cc–2 stroke 250cc–4 stroke	15–18 years	Green	White
Senior B 350cc	350cc–4 stroke	15–18 years	Blue	White
<b>International and European Classes</b>				
FIME 125cc	125cc–4 stroke	10–16 years	Green	White
European Cup				

FIM 125cc Gold Trophy	125cc-4 stroke	12-16 years	Green	White
FIM 250cc Gold Trophy	250cc-4 stroke	14-17 years	Blue	White

Where yellow, green or blue are required the colours shall comply with BS4800: 1972 as follows:  
 Yellow 10E526 Green 14E53 Blue 18E53.

Any other number plate or any marking on the motorcycle that might be confused with a number plate must be removed before the rider is allowed to start.

**8.6 UPGRADING**

On reaching the minimum age for the next group, the rider may upgrade. Please note that any rider who chooses to upgrade cannot then move back to the lower age group once they have competed at a higher level.

A rider may be upgraded into the next higher group before reaching the age normally required subject to the following:

- a) The written agreement of the parent or guardian plus  
 An endorsement by a current Youth Organiser plus  
 The written approval of the Track Racing Committee
- b) For upgrading from Senior class to Dual Youth/Adult 250cc or 350cc competition:  
 The written agreement of the parent or guardian plus  
 An endorsement by a current Youth Organiser plus  
 An endorsement by a National Grass Track Coach plus  
 The written approval of the Track Racing Committee.

In limited circumstances, the Track Racing Committee may give approval to a rider remaining in a lower class for an additional year following written application. Where approval is given, the rider will not qualify for any National Championship points for that year.

**8.7 AWARDS**

Cash awards or gift vouchers are not permitted in Youth events.

**8.8 HOLDER OF A SPEEDWAY CONTRACT**

Riders in possession of an Elite League contract to a BSPA promoter will not be permitted to compete in Youth Grass Track events.

**8.9 CONDUCT**

Riders, parents, guardians or associates failing to obey instructions given by Officials of a meeting or deemed to have unjustifiably or maliciously jeopardised the efficient running of the meeting, will be dealt with in accordance with the National Sporting Code.

**8.10 MINORITY CLASSES**

If a group has an entry of four or less, the Clerk of the Course, with agreement of the Secretary of the Meeting and parents, will decide if those riders will ride with the group above or below the group the riders normally ride in. This should normally be the minority group either side, but only at below National status level.

**8.11 STARTER'S ORDERS**

Only those riders/passengers in the starting area or on a grid will be deemed to be under Starter's Orders. No other rider is subsequently permitted to start in a race.

No parents or mechanics will be allowed on the start area once riders have come under Starter's Orders. The only exception being the Auto Cadet and Cadet classes. A parent or mechanic of a rider

in this group will be permitted on the start provided they stand at least six feet/2 metres from the rear of the machines at the starting gate.

### 8.12 CLOTHING

As per Grass Track Standing Regulation 3.2.

## SECTION 9 GRASS TRACK EVENTS HELD ON SPEEDWAY CIRCUITS

To be implemented where ACU Clubs hold events on Speedway tracks. The ACU Grass Track Regulations shall apply to all Speedway events, where appropriate and the following Supplementary Regulations will become applicable when events of this nature are held.

- 9.1 Affiliated ACU Clubs will only be granted permits to enable them to compete on Speedway tracks that are licensed by the Speedway Control Bureau and maintained to the minimum standard for Speedway.
- 9.2 The Centre within which the circuit is based will normally issue permits for these events.
- 9.3 A Steward will be appointed by the Permit Issuing authority who will conduct a track inspection prior to the event.
- 9.4 The maximum number of riders in each race shall be four.
- 9.5 Machines and capacities shall be as in current ACU Grass Track Standing Regulations.
- 9.6 Youth riders must only compete against others in their age groups as in Grass Track Standing Regulations.
- 9.7 There must be Marshals on the inside of the track as per Grass Track safety requirements, and red warning lights may only be used as a supplement and not in place of the marshals' warning flags.
- 9.8 Two WARNING NOTICES (Type A) must be prominently displayed on either side of the track entrance.
- 9.9 PROHIBITED NOTICES must be displayed in areas to inform spectators of safe areas.
- 9.10 No parents or unauthorised persons other than officials shall be allowed on the track or centre green during practice or racing.
- 9.11 No parents and/or spectators other than mechanics or Officials shall be allowed in the Pit area during practice or racing. No riding will be allowed in the pits.
- 9.12 Any rider who causes a race to be stopped will be excluded.
- 9.13 Any rider who breaks the starting tapes or cause unreasonable delay at the start may be excluded by the Referee or Clerk of the Course.
- 9.14 Ambulance and First Aid cover must be in line with ACU Grass Track Standing Regulations.
- 9.15 Track marking and starting gates will be made with white chalk and kept in good condition throughout practice and racing.
- 9.16 With Youth riders, Organisers are to ensure that a run off area is provided on the inside straights so that riders may leave the track during a race. This is particularly required where kerbstones are used on the inside straights.

## SECTION 10 TRACK RACING OFFICIALS

### QUALIFICATIONS AND CONDITIONS

Track Racing Officials are divided into two categories: those who are Licensed and those who are Registered.

No fees are payable in respect of any Licence or Registration for the appropriate form of identification issued.

**LICENCES:** Senior Track Racing Officials are required to hold an ACU Licence of the appropriate grade for the performance of their duties.

**REGISTRATION:** A register is maintained by the ACU of all licenced Officials.

**TRACK RACING OFFICIALS WHO REQUIRE A LICENCE**

See note below regarding whether a licence and attendance at an ACU seminar is required

	Licence Required	Attendance at Seminar/Training Session
Clerk of the Course	YES (which lasts for 3 years)	YES, every third year maximum
Chief Steward	YES (which lasts for 3 years)	YES, every third year maximum
Chief Technical Officer	YES (which lasts for 3 years)	YES, every third year maximum
Sound Inspector	YES (which lasts for 3 years)	YES, required for first issue only
Measurer	YES (which lasts for 3 years)	YES, required for first issue only

Clubs and Centres shall only nominate candidates whose aptitude and integrity for the position they can fully justify. Official ACU approval and the issue of a licence is only after the candidates have proved to be competent according to the special requirements for each discipline. The respective Committees and Panels organise seminars that are compulsory for certain Officials. A licence is valid for 3 years.

**Note 1 Clerk of the Course Grades/Levels – Track Racing**

**Restricted/Centre** – must undergo training at a seminar organised by a National Clerk of the Course.

**National** – must attend a seminar organised and presented by the ACU Track Racing Committee.

**International** – must attend a seminar organised and delivered by the FIM.

**Note 2 Chief Steward Grades/Levels**

**Restricted/Centre** – will be appointed by the Centre as the Permit Issuing Authority.

**International/National** – will be appointed by the Track Racing Committee as the Permit Issuing Authority.

**Note 3 Chief Technical Official** – will be licenced by the Technical Panel. The Chief Technical Official will be responsible for the Technical Control at an event. The Technical Panel may restrict the disciplines of licence holders.

**Note 4 Measurer** – the Measurer is required for ACU National Championships and National status events. The licence is issued by the Technical Panel and may be restricted by discipline.

**Licence Fees:** All ACU Officials licences will be issued, free of charge by the ACU, for a period of three years.

**TRACK RACING OFFICIALS WHO DO NOT REQUIRE A LICENCE**

See note below regarding requirement for training

**Incident Officer:** may attend Clerk of the Course seminars held at ACU HQ to assist in his/her understanding of the safety requirements needed for organising and staging a successful event.

**Secretary of the Meeting:** will receive training at events via mentoring from personnel within the club or via support from another club’s Secretary of the Meeting.

*NB: an ACU Secretary of the Meeting Guidance booklet is available for reference purposes*

**Technical Official:** will receive training via the Chief Technical Officer at race meetings. May also attend Regional training seminars.

**Club Stewards:** may attend Regional or ACU HQ seminars for information purposes.

**Chief Marshal:** may receive training and mentoring by the Clerk of the Course.

*NB: an ACU Marshals Guidance booklet is available for reference purposes*

**Marshal:** may receive training and mentoring by the Clerk/Assistant Clerk of the Course or Chief Marshal.

*NB: an ACU Marshals Guidance booklet available for reference purposes*

**Medical Officer:** should be a qualified Medical Practitioner or Paramedic – training for this Official is not supplied by the ACU.



All other Technical Officials, Race Day Officials (e.g. Secretary of the Meeting, Incident Officer, Club Stewards) and Marshals may be registered, free of any charge. All such Officials may or may not be required to attend a seminar. Registration will be renewed annually. Registered Officials and Marshals will receive an appropriate form of identification from the ACU.

- Note 1 Incident Officer:** will collate all information and documentation, and prepare reports relating to serious accidents and to all incidents involving Officials or spectators. A Deputy Clerk of the Course may undertake these duties. An Incident Officer may be nominated to attend a Clerk of the Course seminar to assist with these duties.
- Note 2 Secretary of the Meeting:** will be responsible for all administration connected with the organisation of a race meeting.
- Note 3 Club Stewards:** will together with the Chief Steward, form the Judicial authority for the running and overseeing of the race meeting.
- Note 4 Rider Liaison Officer:** may be appointed to assist the Clerk of the Course. It is recommended that a Rider Liaison Officer should hold at least a Regional Clerk of the Course licence. It is also strongly recommended that a Rider Liaison Officer is appointed by the organising club when staging higher status events (e.g. British Masters/National Championships).

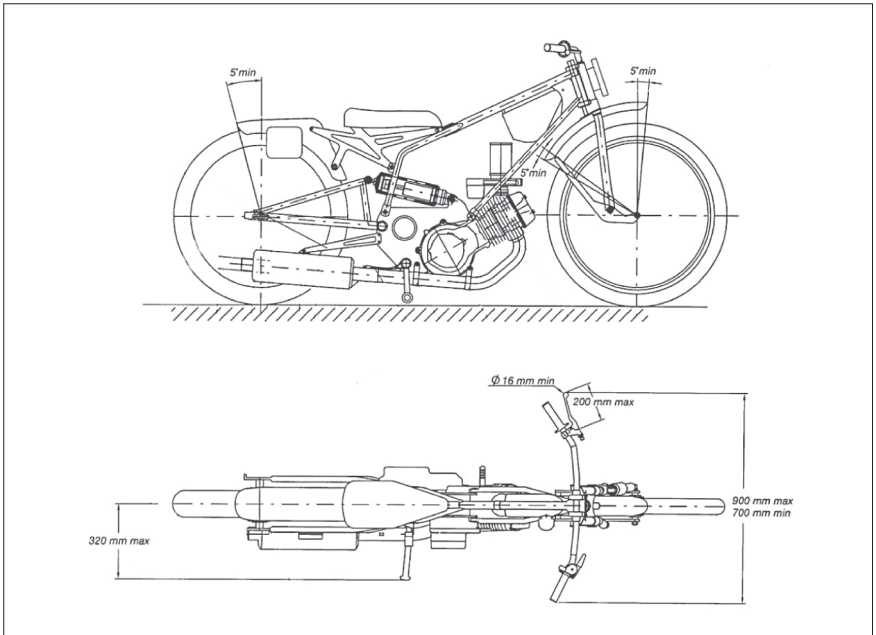

Track racing motorcycle

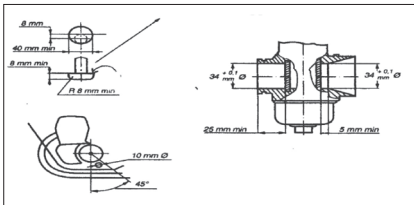

500cc solo only

